

## Info Letter No. 19

# The evaluation of power quality and detection of interference in medium voltage networks

For various reasons, interest in the continuous monitoring of network quality in medium-voltage networks has been increasing rapidly. The same thing applies for electricity as for any other product, quality assurance. Valuable information concerning network conditions is also available.

### Introduction to MV networks:

Medium voltage networks (6 to 64 kV) are usually implemented as compensated networks. Networks with low spatial expansion are implemented with an insulated neutral point, in extensive networks and cable networks a Petersen coil is used. From 132 kV, networks are always solidly earthed.

When there is an earth fault in a conductor in the MV network, the voltage of the two healthy phase increases with respect to earth by a factor of 1.73 (external conductor voltage). This means a greater load on the insulation of this conductor and all other components (insulators, transformer..), which can cause an additional earth fault (double earth fault) or a network short circuit.

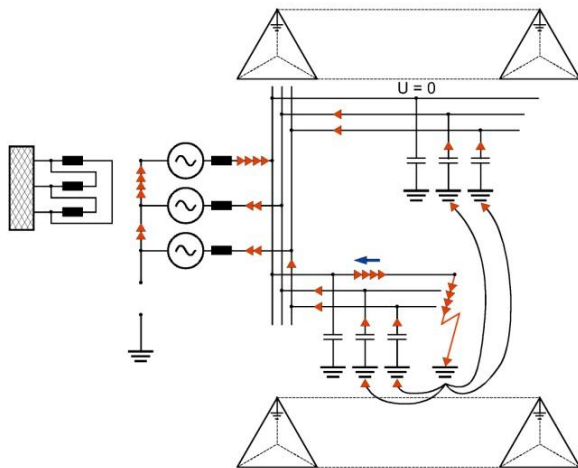

Figure 1 Isolated Network

If an inductance (Petersen coil) is connected between network neutral point N and earth E, an inductive earth fault inductance current flows through it that can compensate for the capacitive earth fault current at the fault location, with suitable dimensioning of the inductance. Nothing changes with respect to the increase in the voltage in the healthy conductors.

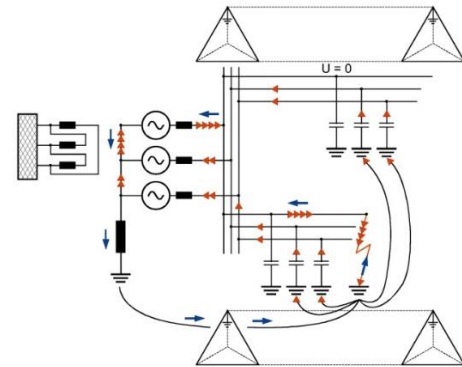
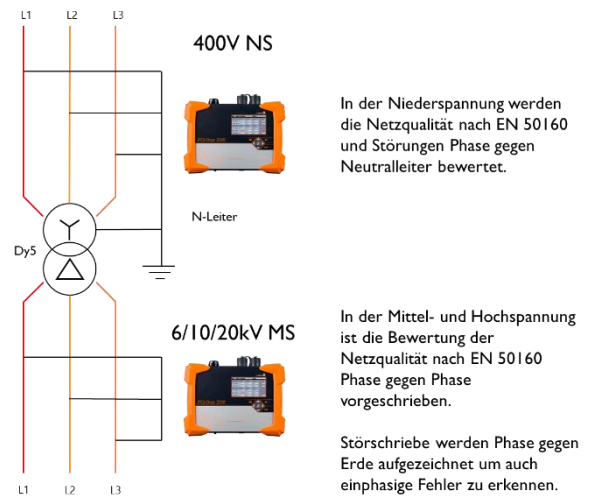

Figure 2 Compensated Network

What type of connection should be chosen for the measurement of fault records and for assessing the voltage quality in accordance with EN 50160?

### EN 50160 in LV and MV networks



### Measurement example:

Measurement of phase to earth.

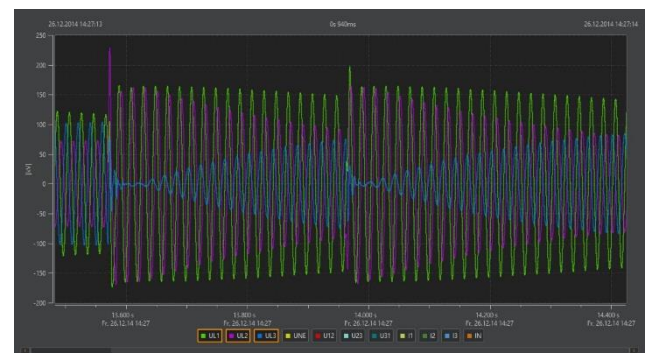

Figure 3 Oscilloscope image U1N, U2N, U3N

With this reoccurring single-phase earth fault in a 110 kV network, the increase in the two healthy conductors and the factor of 1.73 can be easily seen.

Recording of the same fault as a 10ms RMS record of the phase - earth - voltages

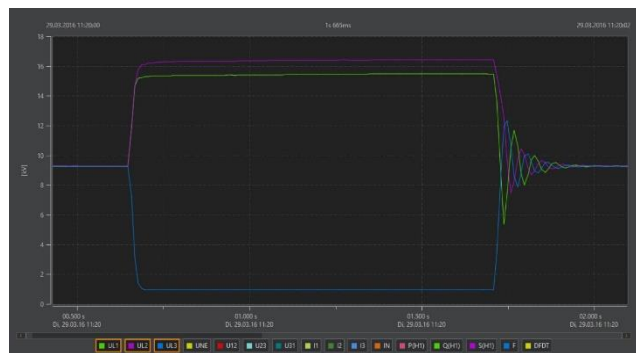

Figure 4 U1N, U2N, U3N, UNE

Using these recordings it is possible to be able to assess the nature of the fault in an MV network, but the effect of this error on the low-voltage network cannot be identified.

For the assessment of the fault that has been detected at the low-voltage side or the end consumer has noticed, the phase-to phase fault is evaluated because a consumer that is supplied with a voltage across a transformer is only supplied on the low voltage side.



Figure 5 Recorder as 10 msec. RMS value U12, U23, U31

In this phase-phase recording, a drop in the medium voltage of 1% can be seen, which the end consumer has also received as approximately 1% would hardly have noticed.

All of the limits in the EN 50160 standard (flicker, harmonic, voltage fluctuations, network imbalance, etc.) in the medium voltage network are with reference to the concatenated voltages. Conversion of an effective measured value over the continuous voltages is no longer possible respectively.

EN 50160 does not apply for high-voltage networks, here the standards are IEC 61000-3-6 for harmonics and 61000-3-7 for flicker with lower limit values as specified in EN 50160.

Areas of application of EN 50160 / IEC 61000-3-6/7

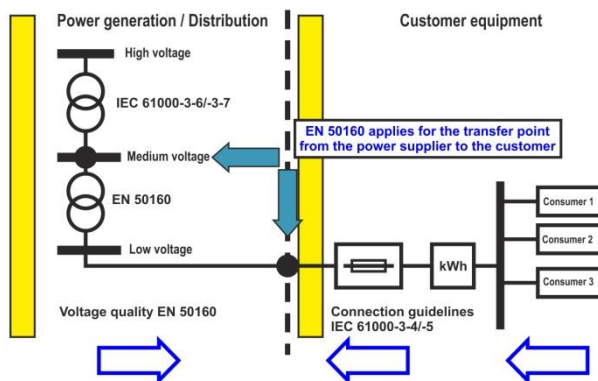

Parameter from EN 50160 with limits for the public low-voltage network and medium-voltage network.

Characteristics of the Supply Voltage	Value or Range of Values		Measurement and evaluation parameters			
	Low voltage	Medium voltage	Base unit	Integration interval	Monitoring period	% rate
Frequency (when connected to a power grid)	49.5 Hz to 50.5 Hz (+/- 1%) 47 Hz to 52 Hz (+4/-6%)		Average Value	10%	1 year	99.5% 100%
Slow voltage changes	230 V +/- 10 %	U <sub>n</sub> +/- 10 %	Effective value	10 min	1 week	95%
Rapid voltage changes (events)	5% max. 10 %	4% max. 6 %	Effective value	10 ms	1 day	100%
Flicker (determination for long-time flicker only)	P <sub>st</sub> = 1		Flicker algorithm	2 h	1 week	95%
Voltage dips (< 1 min)	10 to 1000 per year (less than 95 % U <sub>n</sub> )		Effective value	10 ms	1 year	100%
Short supply interruptions (< 3 min)	a few 10 up to several 100 per year (less than 1 % U <sub>n</sub> )		Effective value	10 ms	1 year	100%
Random long supply interruptions (> 3 min)	a few 10 up to 50 per year (less than 1 % U <sub>n</sub> )		Effective value	10 ms	1 year	100%
Temporary network over-voltages (external conductor - earth)	generally < 1.5 kV	1.7 to 2.0 U <sub>n</sub> (according to neutral point treatment)	Effective value	10 ms	not specified	100%
Transient over-voltages (external conductor - earth)	generally < 6 kV	according to the insulation coordination	Peak value	none	not specified	100%
Voltage imbalance (ratio counter to positive sequence)	generally 2 % in exceptional cases up to 3 %		Effective value	10 min	1 week	95%
Voltage harmonics (reference value, U <sub>n</sub> or U <sub>n</sub> )	Total harmonic distortion (THD) = 8 %		Effective value	10 min	1 week	95%
Inter-harmonic voltage	Value in consultation		Value in consultation			
Signal voltages (reference value, U <sub>n</sub> or U <sub>n</sub> )	Medium voltages: Range 9 to 95 kHz in consultation		Effective value	3 sec	1 day	99%

For example, flicker:

The 2 hour P/t measurement must remain 95% of the time in a week under the limit value of 1.

The series will be continued.

We will gladly supply missing Info Letters at any time!

Issue: 03-2013 / 1019-1-D-1-001-04.docx