

Operating manual

EOR-1DS

Combined earth fault and short circuit indicator



08/2024

Firmware V2.06

NOTICE!

Please note that these operating instructions may not always contain the latest information concerning the device. If, for example the firmware version has changed, then the present description may be incorrect in some points.

In this case please contact us or use the current version of this document on our website (www.a-eberle.de)

A. Eberle GmbH & Co. KG
Frankenstraße 160
D-90461 Nuremberg

Telefon: +49-(0)911-62 81 08 – 0

Telefax: +49-(0)911-66 66 64

E-Mail: info@a-eberle.de

Internet: www.a-eberle.de

The company A. Eberle GmbH & Co. KG does not accept any liability for damage or losses of any kind arising from printing errors or changes in this manual.

Furthermore, A. Eberle GmbH & Co. KG will not accept any liability for loss or damage of any kind resulting from faulty equipment or devices that have been modified by the user.

Table of Contents

1.	User guidance	5
1.1	Target group.....	5
1.2	Warnings	5
1.3	Tips	6
1.4	Other symbols.....	6
1.5	Applicable documentation.....	6
1.6	Keeping	6
1.7	Updated documentation.....	6
2.	Scope of Delivery	7
3.	Safety instructions	8
4.	Technical Data	9
5.	Intended Use	9
6.	Transport and storage.....	9
7.	Installation/Commissioning	10
7.1	Indication unit.....	10
7.2	Terminal assignment C21/C25 current adapter	11
7.3	Terminal assignment U10 voltage adapter.....	11
7.4	Current sensors and mounting SR55 Rogowski sensors	12
7.5	LRM-interface for voltage measurement	15
7.6	Change of SD card	15
8.	External flashing lights and LRM adapter cables.....	16
8.1	External flashing lights	16
8.2	LRM Adapter cables	16
9.	Description and function range	17
9.1	Menu navigation	17
9.2	Settings	19
9.2.1	Short circuit detection	19
9.2.2	Short circuit to earth detection	23
9.2.3	Earth fault detection	25
9.2.4	Remote indication.....	42
9.2.5	Modbus RS485	44
9.2.6	Voltage Measurement	46
9.3	Test and reset	47
9.3.1	Short circuit test.....	47

9.3.2	Earth fault test	48
9.3.3	Binary input.....	49
9.4	System.....	50
9.4.1	General.....	50
9.4.2	Date and time	51
9.4.3	Other settings	52
9.4.4	Operating manual	54
9.5	Switch display off	54
9.6	SD card	55
9.6.1	Files on the SD card.....	55
9.6.2	Copy and save parameter configuration on the SD card	56
9.6.3	Save fault record on a SD card in Comtrade format	56
9.6.4	Firmware update with SD card	57
10.	Modbus protocol	58
10.1	Modbus mode.....	58
10.2	Technical data Modbus interface	58
10.3	datapoint list - register mapping – ‘Standard’	59
10.4	Datapoint list - register mapping “SNH 1.7”	70
11.	Servicing/Cleaning/Spare parts	72
11.1	Firmware update.....	72
11.2	Cold start.....	72
11.3	Spare parts	72
11.4	Cleaning.....	73
12.	Standards and Laws	73
13.	Disassembly & disposal.....	74
14.	Warranty	74
	Notes.....	75

1. User guidance

This User Manual is a summary of the information needed for the installation, commissioning and operation of the EOR-1DS.

Read the User Manual in its entirety and do not use the product unless you have understood the User Manual.

1.1 Target group

The User Manual is intended for skilled technicians as well trained and certified operators.

The contents of this User Manual must be accessible to people tasked with the installation and operation of the system.

1.2 Warnings

Structure of the warnings

Warnings are structured as follows:

 SIGNAL WORD	<p>Nature and source of the danger.</p> <p>Consequences of non-compliance.</p> <p>➡ Actions to avoid the danger.</p>
------------------------------------------------------------------------------------------------------	-----------------------------------------------------------------------------------------------------------------------------

Types of warnings

Warnings are distinguished by the type of danger they are warning against:

 DANGER!	Warns of imminent danger that can result in death or serious injuries if not avoided.
----------------------------------------------------------------------------------------------------	---------------------------------------------------------------------------------------

 WARNING!	Warns of a potentially dangerous situation that can result in death or serious injuries when not avoided.
-----------------------------------------------------------------------------------------------------	-----------------------------------------------------------------------------------------------------------

 CAUTION!	Warns of a potentially dangerous situation that can result in fairly serious or minor injuries when not avoided.
-----------------------------------------------------------------------------------------------------	------------------------------------------------------------------------------------------------------------------

NOTICE:	Warns of a potentially dangerous situation that if not avoided could result in material or environmental damage.
----------------	------------------------------------------------------------------------------------------------------------------

1.3 Tips



Tips on the appropriate device use and recommendations.

1.4 Other symbols

Instructions

Structure of the instructions:

↻ Instructions for an action.

↪ Indication of an outcome, if necessary.

Lists

Structure of unnumbered lists:

- List level 1
- List level 2

Structure of numbered lists:

- 1) List level 1
- 2) List level 1
1. List level 2
2. List level 2

1.5 Applicable documentation

For the safe and correct use of the product, observe the additional documentation delivered with the system as well as the relevant standards and laws.

1.6 Keeping

Keep the user manual, including the supplied documentation, readily accessible near the system.

1.7 Updated documentation

The latest version of the documentation can be downloaded from

<https://www.a-eberle.de/de/downloads>.

2. Scope of Delivery

The scope of delivery contains the displaying unit (EOR-1DS) for detection of earth faults and short circuits. The indicator has an integrated LRM port and current & voltage low power sensor inputs. Depending on the chosen order code additionally a current adaptor for conventional current transducers or three SR55-sensors (rogowski coils) for current measurement are included. The following options are available:

Article-Nr.	Included components
119.9006.10xx	EOR-1DS without additional current sensors
119.9006.11xx	EOR-1DS with 3x rogowski coil current sensors (SR55)
119.9006.21xx	EOR-1DS with plug-on adapter for measurement of 1x 3I0 + 3x Ix
119.9006.25xx	EOR-1DS with plug-on adapter for measurement of 1x 3I0
119.9006.xx06	EOR-1DS with low power voltage sensor inputs with 200 kΩ burden
119.9006.xx07	EOR-1DS with low power voltage sensor inputs with 2 MΩ burden
119.9006.xx10	EOR-1DS with U10 adapter for voltage measurement

Example: A device with 3x rogowski coil current sensors and LRM and low power voltage sensors with 200 kΩ burden has the article number 119.9006.1106.

For operation without external voltage supply, a long life capacitor is included instead of a backup battery.



The adaptor cable for connection of the voltage measurement to the LRM-port is not included in the delivery (more information are provided in the technical datasheet).



Additional, a blinking lamp and low power sensors are available for the EOR-1DS. More information are provided in the technical datasheet.

3. Safety instructions

- Observe the operating instructions
- Always keep the operating instructions with the unit.
- Make sure that the device is never operated in a damaged or compromised condition.
- Make sure that only specialized personnel operate the unit.
- The device must be connected according to the manufacturer's installation instructions.
- Make sure that the device is never operated beyond its stated ratings
- Do not operate the unit in any hazardous environment where explosive gases, dust or fumes occur.
- Ensure that protective covers are always in place and are functional
- Ensure that the five safety regulations according to DIN VDE 0105 are always observed.
- Clean the appliance only with commercially available detergents.

4. Technical Data

Please see the latest EOR-1DS data sheet for this data, which can be downloaded from the download center on our homepage www.a-eberle.de.

5. Intended Use

The Earth Fault and Short Circuit Indicator EOR-1DS is intended for fixed installation and the continual measurement, monitoring and evaluation of voltages and currents.

The EOR-1DS is exclusively intended for use in electrical power engineering facilities and installations, where professionals carry out the necessary work. Professionals are defined as people who are familiar with the installation, assembly, commissioning and operation of such products. They have qualifications that meet the requirements of their activities.

The earth fault and short circuit indicator EOR-1DS complies with the laws, rules and standards applicable at the time of delivery, in particular with relevant safety and health requirements.

In order to maintain this condition and ensure safe operation, the operator must follow all the instructions and warnings in the user manual and the technical data must be observed.

A. Eberle GmbH & Co. KG accepts no liability for damage resulting from unauthorized or improper modification or use of the product. Improper modifications of the product without consultation with A. Eberle GmbH & Co. KG can lead to personal injury, property damage and malfunctions.

6. Transport and storage

The devices shall be stored in dry and clean rooms.

For storage of the device or related spare parts a temperature range from -25 °C to +65 °C is valid.

The relative humidity must not cause condensation or icing.

It is recommended to connect the devices to a power supply before fielding. Especially when the devices shall be applied in extreme climate conditions (e.g. tropical conditions) by this pre-heating condensation can be prevented.

Before the device is connected to power supply for the first time it is recommended to store the device at minimum two hours in the operating room to achieve a temperature balance and to prevent humidity and condensation.

7. Installation/Commissioning

7.1 Indication unit

PIN	Function
1	Modbus GND
2	Modbus A
3	Modbus B
4	Reset extern (use only potential free)
5	Common (Reset extern / Test extern)
6	Test extern (use only potential free)
7	Current sensor L1
8	Current sensor L1 GND
9	Current sensor L2
10	Current sensor L2 GND
11	Current sensor L3
12	Current sensor L3 GND
13	Current sensor 3I0
14	Current sensor 3I0 GND

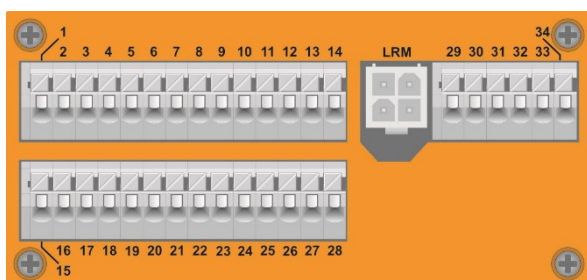

Figure 1: Pins EOR-1DS

PIN	Function
15	Auxiliary voltage 20..240 VDC / 48..240 VAC
16	Auxiliary voltage 20..240 VDC / 48..240 VAC
17-19	not used
20	Flashing lights BL4.1/BL6/BL7 (brown)
21	Flashing lights BL4.1/BL6/BL7 (white)
22-23	not used
24	Relays 1..4 Common
25	Relay 1 / status
26	Relay 2
27	Relay 3
28	Relay 4

PIN	Function
LRM	4 pin socket for LRM system (U-measurement)
29	Voltage sensor L1
30	Voltage sensor GND
31	Voltage sensor L2
32	Voltage sensor GND
33	Voltage sensor L3
34	Voltage sensor GND

7.2 Terminal assignment C21/C25 current adapter

 **DANGER!**

Danger to life because of electric shock!

- ➔ EOR-1DS indicator and current sensors must not be mounted in energized state
- ➔ Ensure that the five safety rules are observed

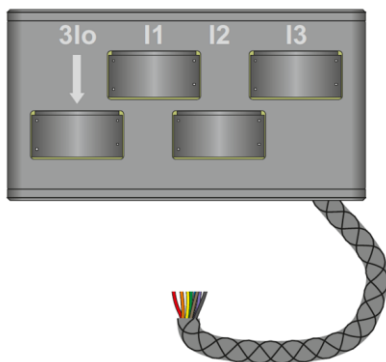

PIN indicator	Function	Cable colour
7 (only C21)	Current sensor L1	Orange
8 (only C21)	Current sensor L1 GND	Red
9 (only C21)	Current sensor L2	Green
10 (only C21)	Current sensor L2 GND	Yellow
11 (only C21)	Current sensor L3	Violet
12 (only C21)	Current sensor L3 GND	Blue
13 (C21 & C25)	Current sensor 3I0	Brown
14 (C21 & C25)	Current sensor 3I0 GND	Black

7.3 Terminal assignment U10 voltage adapter

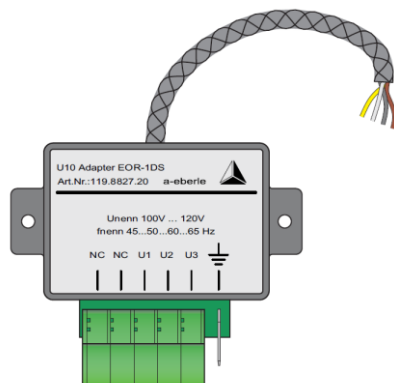

PIN indicator	Function	Cable colour
29	Voltage L1	Brown
30	Voltage GND	Yellow
31	Voltage L2	White
33	Voltage L3	Grey



The Terminals 30, 32 and 34 are internal connected.

7.4 Current sensors and mounting SR55 Rogowski sensors

⚠ DANGER!

Danger to life because of electric shock!

- ➡ EOR-1DS indicator and current sensors must not be mounted in energized state.
- ➡ Ensure that the five safety rules are observed

The sensors can be installed on one-phase cables with a diameter from 13 to 55 mm. The sensors are fixed with cable ties. The installation only requires a few steps and normally can be done very easily in less than a minute.

Please note: the cable shield has to be passed through the sensor back again, per phase respectively.



Abbildung 2: Phase sensor SR55 with label for installation direction P1 / P2 and phase L1 / L2 / L3



The phase sensors SR55 are labelled according to above figure regarding installation direction P1 / P2 and phase L1 / L2 / L3 and have to be mounted accordingly in the correct direction and allocation around the medium voltage cables.

Step 1:

- ➡ For easy mounting it is recommended to fix a cable tie to the cable first.





The cable shield has to be passed through the sensor back again, per phase respectively, see step 2!

Step 2:

- ➔ The sensor can be opened on the joint and therefore laid around the cable afterwards.



Step 3:

- ➔ The already installed cable tie is laid around the upper bracket of the sensor and is then tightened.



Step 4:

- ➔ A second cable tie is mounted on the bottom side of the sensor and tightened as described before.



Step 5:

- ➔ Cut off the protruding parts of the cable ties.



Completely mounted sensor!



For high measurement accuracy the sensor should be vertical to the cable. If only one cable tie is used this criterion is not necessarily fulfilled.



By using a second cable tie the sensor is vertical to the cable. Furthermore, an accidental opening of the sensor is prevented.



7.5 LRM-interface for voltage measurement

For measuring of voltage the EOR-1DS can be coupled with a LRM-system, which means it can be connected in parallel to a voltage indicator (e.g. Capdis or WEGA). The burden of the LRM input of the EOR-1DS is 10 M Ω .



Figure 3: LRM Y-adapter



The EOR-1DS does not provide a second capacity for measurement of the voltage on a capacitive voltage divider. An appropriate device has to be used that provides a capacity corresponding to the capacitive voltage divider (e.g. Capdis or WEGA system). The EOR-1DS can only be connected in parallel to such a device with a LRM – adapter cable.

7.6 Change of SD card



CAUTION!

To avoid damage at the device by transient overvoltages during change of SD card, damage on the SD card itself, and in order to reduce the danger of an electric shock despite reinforced insulation to a minimum, it is recommended for the EOR-1DS before the change of SD card to:

- 1.) Separate EOR-1DS from power supply
- 2.) Use of an ESD wristband

For the change of SD card, for uploading a predefined parameter set or firmware or to save records and logbooks, the front plate of EOR-1DS has to be removed by loosening the screw right hand sight.



Figure 4: EOR-1DS with demounted front plate for SD card access

After changing SD card the front plate must be mounted again, before switching on the power supply again.

8. External flashing lights and LRM adapter cables

8.1 External flashing lights

Optional the external flashing lights type BL4.1 and BL7 for wall mounting and BL6 for surface mounting are available. Typ BL7 verfügt zusätzlich über eine Richtungsanzeige.



Figure 5: Type BL4.1



Figure 6: Type BL7



Figure 7: Type BL6

Type	Description	Cable length	Article number
BL4.1	Without direction indication for wall mounting	6m	119.9100.06
BL7	With direction indication for wall mounting	6m	119.9103.06
BL6	Without direction indication for surface mounting	6m	119.9102.06

8.2 LRM Adapter cables

In addition, the following LRM – adapter cables are available optionally for connection of the voltage of a LRM – system to the AMP socket of the EOR-1DS:



Figure 8: LRM adapter



Figure 9: Y-LRM adapter

Type	Description	Article number
LRM adapter	4 pole AMP-socket on both ends	582.8114.xx
Y-LRM adapter	3x flat plug / socket on 4 pole AMP socket	582.8113.xx



The EOR-1DS does not provide a second capacity for measurement of the voltage on a capacitive voltage divider. An appropriate device has to be used that provides a capacity corresponding to the capacitive voltage divider (e.g. Capdis or WEGA system). The EOR-1DS can only be connected in parallel to such a device with a LRM – adapter cable.

9. Description and function range

In the following chapters the functions and parameters of the device are explained based on the menu structure. Furthermore the algorithms used by the device are explained by giving background information.

9.1 Menu navigation

The display is normally in standby-mode. By pushing the push/turn button on the front panel of the device the display gets activated.

On the very first page possibly detected short circuits and earth faults are displayed.

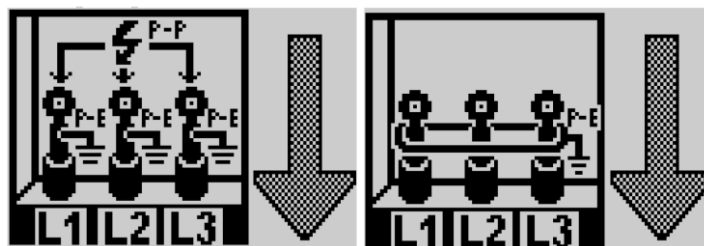

Figure 10: Three-phase short circuit (left) and qu2 earth fault in cable direction (right)

After pushing the push/turn button again the following overview pages are available. Via scrolling with the button it can be switched between the different overview pages.

a-eberle	←→	a-eberle	←→	a-eberle	←→
Status:		summary 1/2:		summary 2/2:	
L1	Status OK	methode relay		methode relay	
L2	Status OK	>I	ON R12--	Uerd	ON R----
L3	Status OK	>Ie	OFF R--3-	---	OFF R----
E	Status OK	Wisch	OFF R----	---	OFF R----
		Puls.	ON R---4	---	OFF R----
		a-eberle	←→	a-eberle	←→
		system 1/2:		system 2/2:	
F	50.0 Hz	T	08:13:12		
FW	Ver. 36	D	04/01/2020		
HW	Ver. 16	🔋	92 %		

Figure 11:

- Status Status of the three phases and ground
- Summery 1 Overview of activated algorithms and relay assignments
- Summery 2 Overview of activated algorithms and relay assignments
- System 1 network frequency, firmware and hardware version
- System 2 time, date and battery condition

a-eberle			a-eberle		
current:			Vol. Unom = 20 kV		
I1	23	A	U1	11.7	KV
I2	22	A	U2	11.6	KV
I3	23	A	U3	11.7	KV

a-eberle			a-eberle		
ψ:			3I0, U0, ψ0		
ψ1	0.2	°	3I0	0.8	A
ψ2	0.3	°	U0	0.2	KV
ψ3	0.1	°	ψ0	0.5	°

Figure 12: Overview pages for current, voltage, phase angle and zero sequence system

a-eberle		a-eberle	
PQS total:		active power:	
P	302 kW	P1	120 kW
Q	299 kVar	P2	123 kW
S	42 kVA	P3	119 kW
F	50.1 Hz	P0	3 kW

Figure 13: Overview PQS total and overview active power

By pushing the button another time the main menu is activated. The main menu in detail is explained in chapter 9.2. The path of the actual menu is indicated by the numerical sequence in the headline of the submenu. By turning the push/turn button it can be chosen between one of maximum six options. By pushing the button the chosen option is confirmed.

→ 1	→ 1.1.2.1
Main Menu:	qu2-param. (1/2)
setting	Ice, min.
→ test/reset	resetime tran.
system	permanent fault
display off	→ retriggerable
SD card	next
back	back

Figure 14: Main menu and submenu qu2-param.

In the parametrization menu of the actual parameter the current value of the parameter is shown in the bottom part of the display. By pushing the button a parameter change is confirmed.



Via „back“ it is always possible to switch back to the next higher level of the menu. Furthermore, on parametrization pages where parameters can be changed it is possible to cancel the current process by pushing the button for at least 3 s.

9.2 Settings

9.2.1 Short circuit detection

The EOR-1DS is able to perform undirected as well as directed short circuit detection. For the undirected short circuit detection only the fault current is evaluated. For the directed short circuit detection the fault angle between fault current and fault voltage is evaluated, provided that the configured current threshold and configured threshold time are exceeded.

The angle of triggering is set in the device and not adjustable. For suppression of a back and forth in the directional indication in borderline cases additionally a deadband is implemented. In the dead band area no direction is indicated. All short circuits in this area are evaluated as undirected.

The following areas are defined in the device:

Forward indication:	80° to -35°
Backward indication:	-100° to -215°
Deadband:	-35° to -100° and -215° to 80°

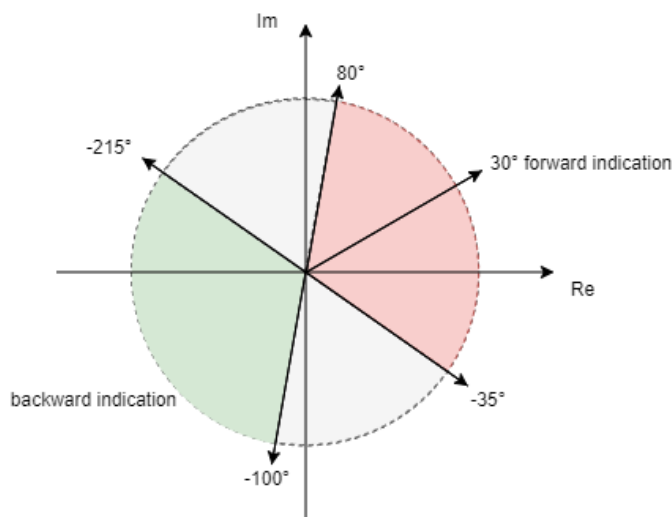



Figure 15: Definition of areas for the directional short circuit indication

In the EOR-1DS for evaluation of the short circuit the voltage U is placed on the real and therefore the angle of the current I is considered (analogue to the calculation of the angle $\varphi = \varphi_U - \varphi_I$ in the EOR-3DS). Electrical lines behave ohmic-inductive in case of a short circuit, which means for fault in cable direction (forward indication) the current lags compared to the voltage. Therefore the forward fault referring to the chosen angle definition in the EOR-1DS is found in the 1st quadrant and the backward fault in the 3rd quadrant.

Additionally to the detection of single short circuits the EOR-1DS is able to detect a second short circuit separately as long as the first short circuit is hold by the device. The second detected short circuit is display with 2.P-P instead of P-P. With the parameters in the >>I folder a second short circuit trip current with the according response delay can be parameterized. In the EOR-1DS there is no additional >>I indication.



The parameters directional indication is only visible in the display when voltage measurement is activated, see chapter 9.2.6.
 This parameter activates directional indication for short circuit and short circuit to earth indication.

Directional indication		
Submenu	[Start page → main menu → settings → short circuit → general → directional]	
Description	This parameter enables the directional short circuit detection. When deactivated all short circuits are indicated as undirected.  The directed short circuit detection is only possible for a response time up to 1000 ms. For higher values of the parameter response time the directional detection is automatically deactivated.	
Depending parameters	Trigger angle	
Shortcut	Value	Default
Directional ind.	On/Off	On

Trip current >I					
Submenu	[Start page → main menu → settings → short circuit → >I/>>I → >I settings → trip current]				
Description	With this parameter the current threshold for triggering the short circuit indication is defined.  The mean value is calculated over 2 periods. For the configuration with a plug-on-current transducer the threshold values are depending on the chosen transformer ratio kni.				
Shortcut	Min. value	Max. value	Step size	Default	Unit
Trip current	OFF or 20	2500	10	200	A

Response delay >I

Submenu [Start page → main menu → settings → short circuit → >I/>>I → >I settings → response delay]

Description When the trip current is exceeded for the parametrized response delay a corresponding short circuit is indicated by the device.

Shortcut	Min. value	Max. value	Step size	Default	Unit
Response delay	20	3000	20	80	ms

Trip current >>I

Submenu [Start page → main menu → settings → short circuit → >I/>>I → >>I settings → trip current]

Description With this parameter the current threshold for triggering the short circuit indication is defined.



The mean value is calculated over 2 periods. For the configuration with a plug-on-current transducer the threshold values are depending on the chosen transformer ratio kni.

Shortcut	Min. value	Max. value	Step size	Default	Unit
Trip current	OFF or 20	2500	10	OFF	A

Response delay >>I

Submenu [Start page → main menu → settings → short circuit → >I/>>I → >>I settings → response delay]

Description When the trip current is exceeded for the parametrized response delay a corresponding short circuit is indicated by the device.

Shortcut	Min. value	Max. value	Step size	Default	Unit
Response delay	20	3000	20	100	ms

Reset time short circuit

Submenu	[Start page → main menu → settings → short circuit → > />> → Reset time]				
Description	Time for automatic reset of the short circuit indication. The timer starts on the detected short circuit occurrence.				
Shortcut	Min. value	Max. value	Step size	Default	Unit
Resetime SC	5 s	18 h	1 s	15 s	HH:MM:SS

Current reset

Submenu	[Start page → main menu → settings → short circuit → > />> → current reset]				
Description	<p>With the automatic current reset only short circuit messages are reset, as soon as the current on the conductor L1, L2 or L3 is higher than the chosen limit for 10 s.</p> <p>This function as an example can be used for a reconnection after a short circuit to reset the short circuit message before the normal short circuit reset time, so that when another short circuit occurs the evaluation starts again.</p>				
Shortcut	Min. value	Max. value	Step size	Default	Unit
Current reset	OFF or 3	50	1	OFF	A

9.2.2 Short circuit to earth detection

The EOR-1DS is able to perform undirected as well as directed short circuit to earth detection. For the undirected short circuit to earth detection only the fault current is evaluated. For the directed short circuit to earth detection the fault angle between zero sequence fault current and fault voltage is evaluated, provided that the configured current threshold and configured threshold time are exceeded.

The zero sequence current is used for evaluation. The EOR-1DS can calculate the current or measure the current with a suitable sensor.

The principle for the directed indication is equivalent to the short circuit detection (see 9.2.1). However, it has to be considered that the angles for the directed indications are inverted compared to the short circuit because the zero sequence measurement values are used.

Trip current >Ie

Submenu [Start page → main menu → settings → short circuit → >Ie/>>Ie → >Ie settings → trip current]

Description With this parameter the current threshold for triggering the short circuit indication is defined.



The mean value is calculated over 2 periods. For the configuration with a plug-on-current transducer the threshold values are depending on the chosen transformer ratio kni.

Shortcut	Min. value	Max. value	Step size	Default	Unit
Trip current	OFF/20	2500	10	100	A

Response delay >Ie

Submenu [Start page → main menu → settings → short circuit → >Ie/>>Ie → >Ie settings → response delay]

Description When the trip current is exceeded for the parametrized response delay a corresponding short circuit is indicated by the device.

Shortcut	Min. value	Max. value	Step size	Default	Unit
Response delay	20	3000	20	80	ms

Trip current >>le

Submenu [Start page → main menu → settings → short circuit → >le/>>le → >>>le settings → trip current]

Description With this parameter the current threshold for triggering the short circuit indication is defined.



The mean value is calculated over 2 periods. For the configuration with a plug-on-current transducer the threshold values are depending on the chosen transformer ratio kni.

Shortcut	Min. value	Max. value	Step size	Default	Unit
Trip current	OFF/20	2500	10	100	A

Response delay >>le

Submenu [Start page → main menu → settings → short circuit → >le/>>le → >>>le settings → response delay]

Description When the trip current is exceeded for the parametrized response delay a corresponding short circuit is indicated by the device.

Shortcut	Min. value	Max. value	Step size	Default	Unit
Response delay	20	3000	20	80	ms

Reset time short circuit to earth

Submenu [Start page → main menu → settings → short circuit → >le/>>le → Reset time]

Description Time for automatic reset of the short circuit indication. The timer starts on the detected short circuit occurrence.

Shortcut	Min. value	Max. value	Step size	Default	Unit
Resettime SC	5 s	18 h	1 s	15 s	HH:MM:SS

9.2.3 Earth fault detection

Depending on the neutral point treatment of the grid different algorithms for earth fault detection can be used: the transient qu2-algorithm or stationary methods (wattmetric method, reactive power method or pulse detection). For better understanding of the earth fault detection methods the general theory and processes of an earth fault event are explained in the following section.

9.2.3.1 Processes of an earth fault event

The earth fault is characterised by one phase of the three-phase system being shorted to earth. Therefore the voltage of the faulty phase collapses. In the healthy phases the voltage increases in compensated and isolated grids. In solidly and low ohmic earthed grids the earth fault becomes an earth short circuit where high currents over earth occur. In all cases and types of neutral point treatment a zero sequence voltage (vectorial sum of phase voltages $\underline{U}_0 = \underline{U}_{1E} + \underline{U}_{2E} + \underline{U}_{3E}$) due to the imbalance occurs. Hence the zero sequence voltage often is used as the basic criterion for earth fault detection. The following three overlapping processes are distinguished:

- Discharging of the defective line via earth
- Charging of the healthy lines via earth
- Steady-state

In the following section these processes are discussed shortly at the example of an isolated grid with three feeders.

Discharging process of the faulty phase

First the capacities to ground of the faulty phase (in the faulty feeder as well as in the healthy feeders) are discharged.

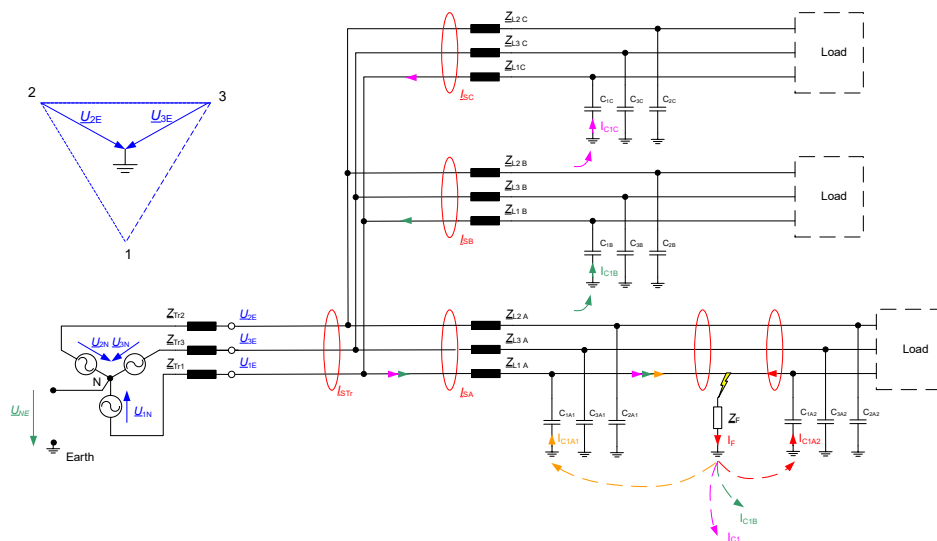

Figure 16: Discharging process for an isolated grid with three feeders

Important for the discharge process are:

- Capacity of faulty phase to earth
- Charging state of the capacity of faulty phase
- Line impedance to and in the other outgoing feeders
- Impedance of the faulty section itself or the earthing

The discharging process affects only the faulty phase and is independent of the neutral point treatment of the grid. The very high-frequency transient process depends on the length of the cables and its frequency gets higher as the cables get shorter. It is usually in the range of >10 kHz. Therefore the discharging process is not evaluated for the earth fault location.

Charging process of the healthy phases

In the second process the healthy phases are charged over earth. Caused by the charging the phase voltages of the healthy phases increase at maximum up to the value of the line-to-line voltage (depending on the fault impedance). This causes a neutral point shift.

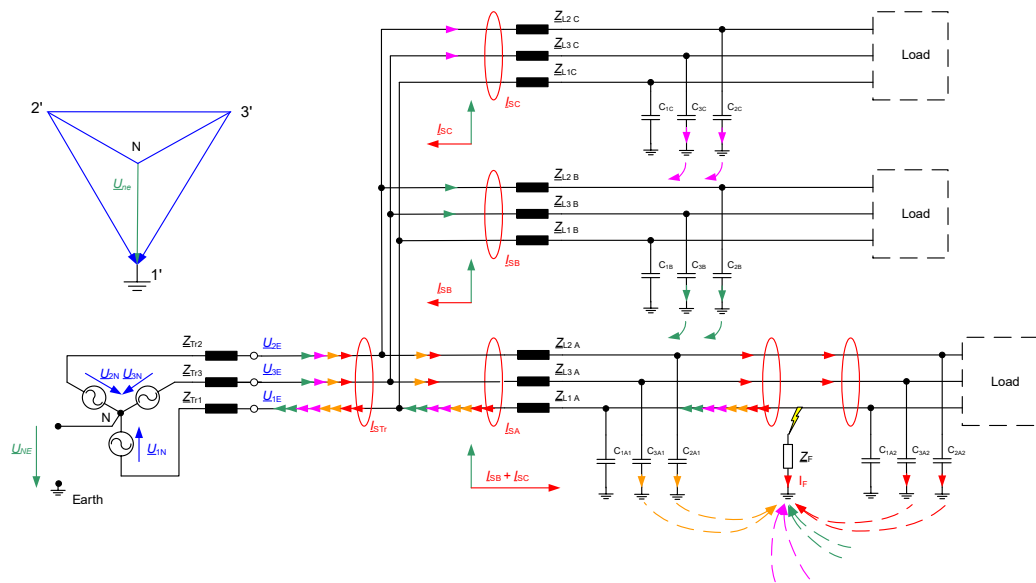

Figure 17: Charging process for an isolated grid with three feeders

Key for the charging process are:

- Capacitance of healthy phases to earth
- Charging state of the phases' capacitance
- Charging voltage
- Leakage inductance from the injecting transformer
- Line impedance from the faulty feeder to the injecting transformer
- Impedance of the fault itself or the earthing

The distribution transformers or the loads are only considered with a high impedance and can be neglected in the first approximation. The charge oscillation's limiting element remains the injecting transformer's relatively low impedance leakage inductance, and, if the faults are very far away, the transformer's inductance to the faulty section.

The charging process for the wye connection is displayed in the equivalent circuit in Figure 18. A possible transformer delta connection can be converted to the equivalent wye connection.

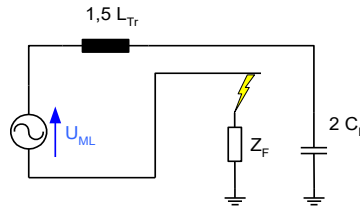

Figure 18: Equivalent circuit for the charging process

The frequency of the charge oscillation is calculated from

$$f_A = \frac{1}{2\pi} \sqrt{\frac{1}{L_{ers} C_{ers}}} = \frac{1}{2\pi} \sqrt{\frac{1}{3 L_{Tr} C_E}} \quad (0.1)$$

This formula for the charge oscillation frequency also applies when the inductance of the transformer L_{Tr} is added to the inductance of the line from the faulty section to the transformer. It reduces the frequency. An earth fault that is very far away delivers a lower charge frequency than an earth fault that is closer to a bus bar.

Estimation of the leakage impedance over the impedance voltage and the transformer's rated apparent power:

$$X_{Tr} = \omega L_{Tr} = \frac{u_s U_n^2}{100 S_{Trn}} \approx \frac{u_k U_n^2}{100 S_{Trn}} \quad (0.2)$$

The initial amplitude of the charging current is given by:

$$\hat{I}_{ZA} = 2 \omega C_E \hat{U}_{ML} c_\phi = \frac{2}{3} \hat{I}_{CE} c_\phi \quad (0.3)$$

The impact of the switching moment (angle φ) is taken into account by the amplitude factor (in the formula, $f = 50$ Hz):

$$c_\phi = \sqrt{\cos^2 \varphi + \left(\frac{f_A}{f}\right)^2 \sin^2 \varphi} \quad (0.4)$$

In the maximum of the earth-line voltage of the faulty line ($\varphi = 90^\circ$)

$$\hat{I}_{ZA} = 0,667 \hat{I}_{CE} \frac{f_A}{f} \text{ an the zero point of the earth-line voltage of the faulty line } (\varphi = 0^\circ) \quad c_\phi = 1$$

$$\text{and } \hat{I}_{ZA} = 0,667 \hat{I}_{CE} .$$

The above derivations have shown that the peak value of the charging current takes on at least the value $0,667 \hat{I}_{CE}$ of the remaining grid (total grid minus faulty feeder).

Transient relays evaluate the charging process. The high frequency discharge oscillations are filtered out.

Steady state

In the steady state, the 50 Hz component of an isolated grid's capacitive current flows across the faulty section. The faulty voltage of the faulty phase remains zero while the voltages of the healthy phases remain on the increased value of the phase to phase voltage (in case of a low

ohmic fault). The steady state corresponds to the conditions in the charging process without charging oscillation as shown in Figure 17. In an isolated grid the capacitive earth fault current I_{CE} flows on the fault location.

9.2.3.2 The basics of resonant earthing

In medium and high voltage grids, Petersen coils are used to compensate the capacitive current across the faulty section by a similarly large counter-flowing inductive current when a single pole-to-earth fault occurs. This is done by setting the coil (in the grid's healthy state) to an inductive reactance X_L that corresponds approximately to the grid's capacitive reactance X_C . A real compensation coil additionally to the inductivity L_P shows an ohmic component G_P .

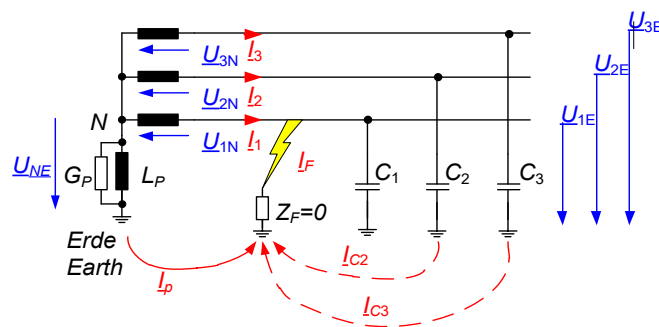

Figure 19: Equivalent circuit of a compensated grid (with only one feeder) with compensation coil and one-pole earth fault

When X_L equals exactly X_C only the so-called wattmetric residual current flows over the fault location. Normally the compensation coil is not exactly tuned to the resonance point (full compensation), but is slightly overcompensated.

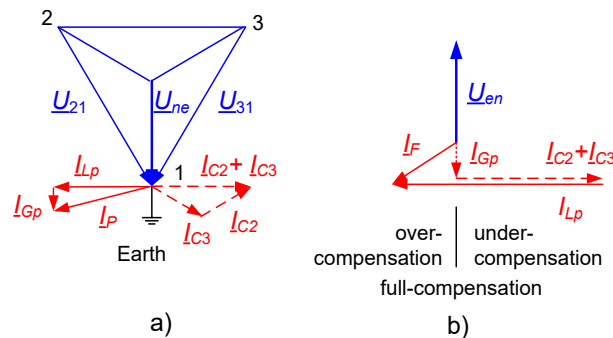

Figure 20: a) Vector diagram with earth fault in phase L1 (fault impedance = 0 Ω)
b) Influence of different positions of the compensation coil on the fault current I_F

In compensated grids the zero sequence currents are significantly reduced compared to the isolated grid. Hence other methods for locating of earth faults have to be used. For the evaluation of the steady state in compensated grids the pulse detection can be used. The evaluation of the transient charging process via qu2-method can be used for both isolated and compensated grids and is therefore very flexible.

9.2.3.3 General

As soon as the Uearth trip value is exceeded, the examination of the active earth fault detection algorithms is started. If the voltage falls below the threshold of Uearth the indication is delayed in addition by the parameter >Ue reset time.

>Ue trip value

Submenu [Start page → main menu → settings → earth fault → general → >Ue trip val.]

Description With this parameter the trigger value for earth fault detection in general is defined. When the zero sequence voltage exceeds this threshold the evaluation of the qu2-method is started.

Shortcut	Min. value	Max. value	Step size	Default	Unit
>Ue trip value	1	90	1	30	%

>Ue reset time

Submenu [Start page → main menu → settings → earth fault → general → >Ue resettime]

Description Time for an automatic reset of the >Ue indication. The timer starts when the zero sequence voltage exceeds the >Ue threshold (when there is no earth fault any more).

Shortcut	Min. value	Max. value	Stepsize	Default	Unit
Resettime >Ue	5 s	18 h	1 s	15 s	HH:MM:SS

The exceeding of the earth fault trip value is indicated with "Ue". When the earth fault is longer active than the parameterised time for the permanent fault (parameter in chapter 9.2.3.4), "Ue PE" is additionally indicated.

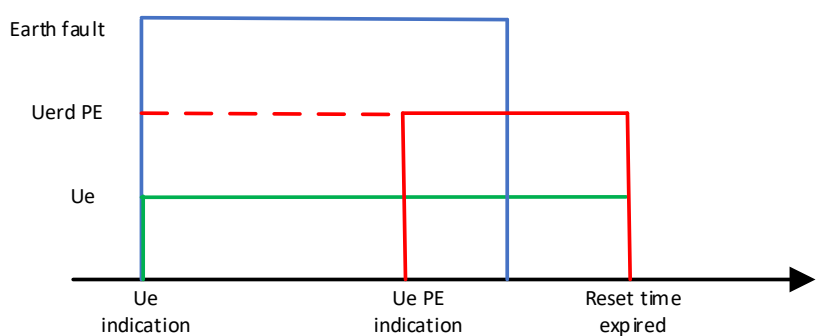

Figure 21: "Ue" and "Ue PE" indication

9.2.3.4 qu2 transient method

The qu2-method (transient method) evaluates the recharging process (see also chapter 9.2.3.1) of the two healthy phases when an earth fault occurs.

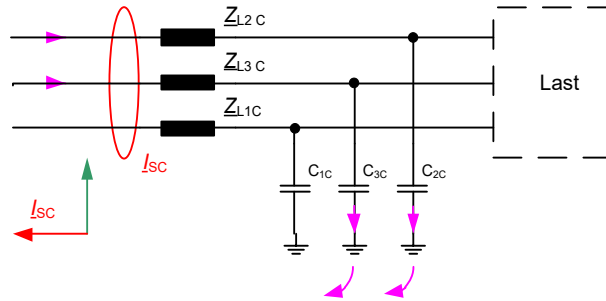

Figure 22: Recharging process of healthy feeder

The curve of the zero sequence voltage can be described in a simplified manner by the following equation: $u_0(t) = \frac{1}{c} \int_0^t i_o(\tau) d\tau$. It shows that the voltage does not occur until a current flows on the line-to-earth capacitance. This creates a current that leads the voltage by 90°. The integrated value of the current can be interpreted here as the applied charge q . This means that the voltage in a fault-free feeder is proportional to the charge. Plotting u_0 and q against in a diagram will always yield a straight line with a positive gradient for the fault-free feeder.

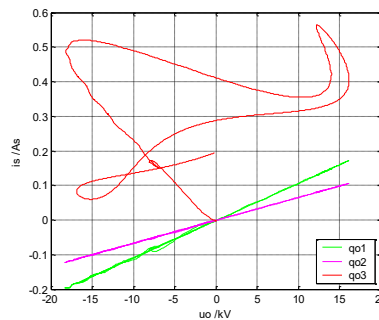

Figure 23: Direction evaluation qu2-methode (faulty feeder qo3)

Based on the fault resistance, the faulty feeder will yield a straight line with a negative gradient or the direction evaluation will be based on the rotation (corresponds to the surface or the curvature of the curve).

Fault-free feeder: Straight line with positive gradient

Faulty feeder: Straight line with negative gradient or rotation

The qu2-method compared to the conventional qu-method is additionally using a linearization on the operating point and nonlinear filters. Therefore a reliable earth fault detection is also possible in meshed grids.



The folder “transient detection”, which contains all parameters for the qu2-method, is hidden in the menu when “voltage over LRM” is switched off, see chapter 9.2.6.

Current threshold Ice min

Submenu [Start page → main menu → settings → earth fault → transient det. → Ice, min.]

Description For triggering the qu2-signal in addition to the Uearth threshold a current threshold has to be exceeded. This parameter correlates to the minimal residual healthy grid (primary value).

The current threshold can be estimated from the capacitive earth fault current I_{CE} of the uncompensated grid.

$$I_{ce,min} = I_{CE} \cdot 0.05$$



With a plug-on current transducer for the configuration the minimum and maximum values for this parameter are depending on the chosen transformer ratio kni.

Shortcut	Min. value	Max. value	Step size	Default	Unit
Ice min	0	100	0.01	5	A

Reset time transient method

Submenu [Start page → main menu → settings → earth fault → transient det. → resettime tran.]

Description Time for an automatic reset of the qu2-transient method indication. The timer starts when the qu2 indication gets active (when the earth fault is detected).

Shortcut	Min. value	Max. value	Stepsize	Default	Unit
Resettime trans.	5 s	18 h	1 s	15 s	HH:MM:SS

Permanent fault

Submenu [Start page → main menu → settings → earth fault → transient det. → permanent fault]

Description ● When the zero sequence voltage exceeds the Uearth trip value for a longer time than the parametrized permanent fault time the device detects a permanent earth fault. In addition to the normal Uearth indication “Ue” the device also sets a corresponding message “Ue_PE”.

Shortcut	Min. value	Max. value	Step size	Default	Unit
Permanent fault	0	60	1	1	s

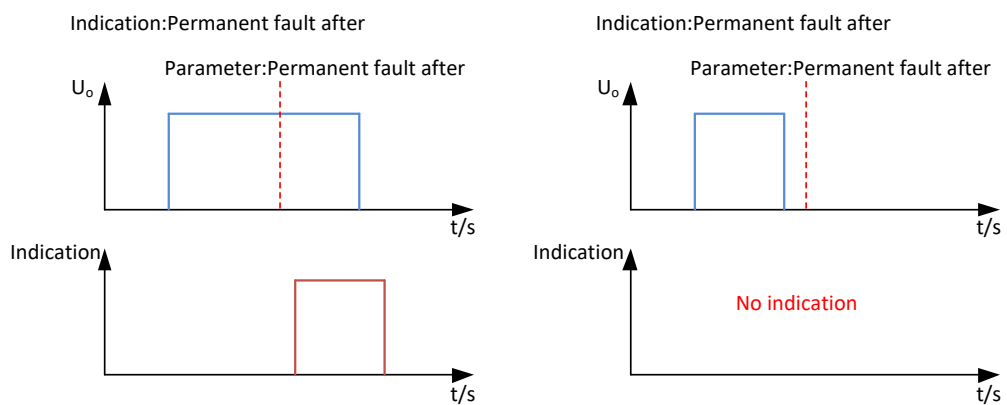

Figure 24: Earth fault indication in case of permanent earth fault

Type of signal/ retriggerable

Submenu [Start page → main menu → settings → earth fault → transient det. → retriggerable]

Description With this parameter it can be chosen between two types of qu2-message:

- Retriggerable (always the latest fault detected by the qu2 is indicated)
- Not retriggerable (the first earth fault detected by the qu2 is saved and indicated until it is reset).

Shortcut	Unit	Default
Retriggerable	ON/OFF	ON

Direction filter		
Submenu	[Start page → main menu → settings → earth fault → transient det. → direct. filter]	
Description	Only the qu2 indication in forward direction is indicated when this parameter this set to "On". Qu2 indications in backward direction are suppressed in that case.	
Shortcut	Unit	Default
Direction filter	ON/OFF	OFF

Rot./Grad.					
Submenu	[Start page → main menu → settings → earth fault → transient det. → rot./grad.]				
Description	<p>With this parameter it can be defined when rotation and when the gradient is used as criterio for the direction of the signal in the qu2-algorithm. When the ratio of the calculated values for rotation/gradient < parameter Rot./Grad. then the gradient is used for evaluation, otherwise the rotaion is used.</p> <p> The parameter is set to 50 per default and normally has not to be adapted. Changes in this parameter should only be performed in consultation with A. Eberle GmbH & Co. KG.</p>				
Shortcut	Min. value	Max. value	Stepsize	Default	Unit
Rot./Grad.	0	360	1	50	-

9.2.3.5 Wattmetric $\cos(\varphi)$ location method for compensated grids

In the $\cos(\varphi)$ location method, the measured total current I_0 is projected to the zero sequence voltage U_0 . Then the active component is calculated from the total current. Here the direction of this active current is decisive for signalling the earth fault in the forward or backward direction.

In this procedure it is also important that the measurement values I_0 and U_0 are accurately measured. This is primarily dependent on the angular accuracy of the current and voltage transformers.

Figure 25 shows the direction evaluation of the $\cos(\varphi)$ method. The measured values U_0 and I_0 are displayed. U_0 is used as reference value. The current I_0 is split in its active and reactive part. For a fault message the active part needs to exceed the parameterized value. Figure 25 shows the areas for the directional signals and the tolerance zone according to the parameterized minimum value and angle.

With an inaccurate measurement (\leq cl. 1) there can be faulty directional indications with the $\cos(\varphi)$ location method with default parameters. To prevent this, the minimum angle is increased. With the parameter "non-directional" an additional non-directional indication for the $\cos(\varphi)$ procedure is activated. This indication appears, when the active current exceeds the parameterized threshold but the minimum angle is not exceeded.

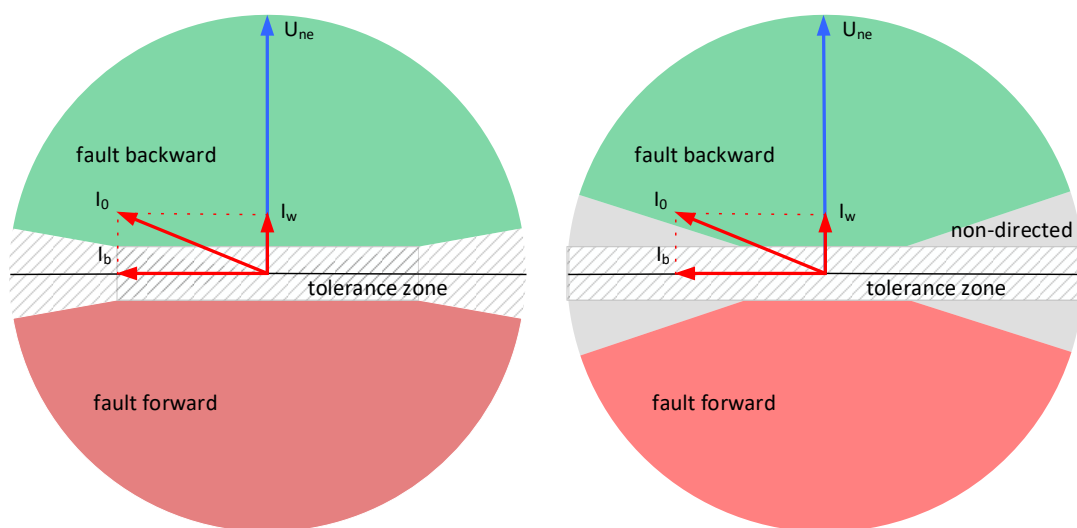

Figure 25: Direction determination $\cos(\varphi)$ procedure

Iw min

Submenu [Start page → main menu → settings → earth fault → Cos(phi) → Iw min]

Description Minimum resistive fraction of the total current at the output.



Only one mode can be active at once.

Here the trigger value can be estimated using the following formula.

Rule of thumb: $I_{w,min} = 0.25 * 0.03 * I_{CE,Grid}$

The total active component of the network can initially be estimated as 3 % of $I_{CE,Grid}$ or e.g. read directly from the electrical coil controller. The trigger value is then determined by multiplying with a safety factor ($f_A = 25 \%$)

Shortcut	Min. value	Max. value	Step size	Default	Unit
Iw min	OFF or 1	1000	1	OFF	A

Angle min

Submenu [Start page → main menu → settings → earth fault → Cos(phi) → Angle min]

Description Minimum angle that must be exceeded to ensure an indication is output. This parameter is used to allow for angular errors of the current and voltage transformers.

Shortcut	Min. value	Max. value	Step size	Default	Unit
Angle min	0°	90°	1°	5°	°

Cycles (x20 ms)

Submenu [Start page → main menu → settings → earth fault → Cos(phi) → Cycles]

Description The same earth fault direction must always be specified for the specified number of measurement cycles.

Shortcut	Min. value	Max. value	Step size	Default	Unit
Cycles	0	10	1	5	-

Reset time cos(φ) procedure

Submenu [Start page → main menu → settings → earth fault → Cos(phi) → tresettime]

Description Time for the automatic reset of the cos(phi) procedure indication.

Shortcut	Min. value	Max. value	Step size	Default	Unit
Resettime	5 s	18 h	1 s	1 h	HH:MM:SS

Non-directional indication $\cos(\varphi)$ procedure		
Submenu	[Start page → main menu → settings → earth fault → Cos(phi) → non-directional]	
Description	With an inaccurate measurement (\leq cl. 1) this parameter can be activated to get a additional non-directional measurement.	
Shortcut	Value	Default
Resetime	ON/OFF	OFF

9.2.3.6 $\sin(\varphi)$ location methode for isolated networks

This location methode is favoured for use in isolated networks. Here the $\sin(\varphi)$ methode evaluates the fundamental of the zero sequence voltage and total current. In this procedure, stationary conditions are prerequisite.

In the isolated network there are, due to the high capacitive currents, unique conditions for measuring the direction of the fault. The advantage of this procedure is that the angular accuracy requirement for the current and voltage transformers is low. For a direction decision here only a 90° decision is made.

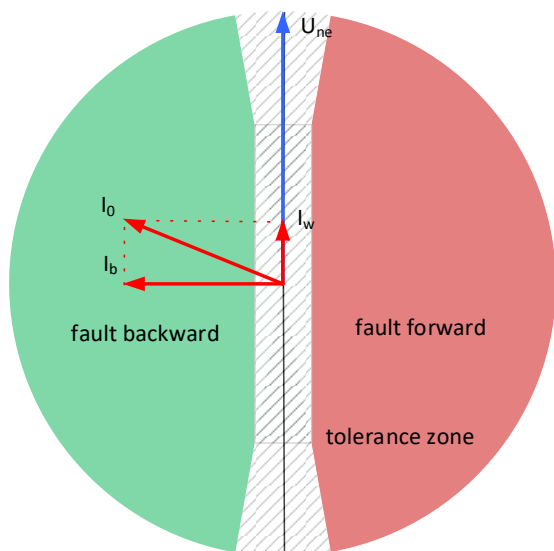



Figure 26: Direction determination $\sin(\varphi)$ procedure

Ib min					
Submenu	[Start page → main menu → settings → earth fault → Sin(phi) → Ib min]				
Description	Minimum current of the fundamental voltage so that a direction decision or signal can be issued.				
	 This value relates to the total, capacitive network earth fault current. Rule of thumb: $I_{b,min} = 0.05 * I_{CE,Grid}$				
Shortcut	Min. value	Max. value	Step size	Default	Unit
Ib min	OFF or 1	150	1	OFF	A

Angle min					
Submenu	[Start page → main menu → settings → earth fault → Sin(phi) → Angle min]				
Description	Minimum angle that must be exceeded to ensure an indication is output. This parameter is used to allow for angular errors of the current and voltage transformers.				
Shortcut	Min. value	Max. value	Step size	Default	Unit
Angle min	0°	90°	1°	5°	°

Cycles (x20 ms)					
Submenu	[Start page → main menu → settings → earth fault → Sin(phi) → Cycles]				
Description	The same earth fault direction must always be specified for the specified number of measurement cycles.				
Shortcut	Min. value	Max. value	Step size	Default	Unit
Cycles	0	10	1	5	-

Reset time sin(φ) procedure					
Submenu	[Start page → main menu → settings → earth fault → Sin(phi) → tresettime]				
Description	Time for the automatic reset of the sin(phi) procedure indication.				
Shortcut	Min. value	Max. value	Step size	Default	Unit
Resetime	5 s	18 h	1 s	1 h	HH:MM:SS

9.2.3.7 Pulse detection

For pulse detection a pulsing device is necessary, that is normally connected to the power auxiliary winding of the arc suppression coil. The pulsing device generates a pulsing current that can be measured only up to the fault location. By swithing on and off a capacity (or inductance) the detuning of the compensated grid and therefore the zero sequence current changes. When condensators are switched on for pulsing the overcompensation is reduced, which causes a shift on the resonance curve to full compensation.

For **low-ohmic faults** the generated zero-sequence current can only flow over the fault location. The voltagess of the healthy phases are not influenced by the pulsing. The capacitive currents in the healthy feeders therefore also remain constant. A pulsing zero-sequence current can therefore be only detected in the faulty feeder.

For **high-ohmic faults** a coupling to the healthy feeders occurs. The pulsing on the fault location now causes a change of the zero-sequence voltage because of the fault impedance. Therefore the voltagess of the healthy phases also change, which in consequence causes the capacitive currents in the healthy feeders to change with the pulse.

For **classic pulse detection relays**, that only evaluate the amplitude of the current, this leads to the problem that with a symmetrical pulse for high-ohmic faults the healthy and faulty feeders can not be differentiated from each other. Therefore an unsymmetrical pulse (e.g. pulse/pause-ratio 1,5/1) must be used for conventional relays. Furthermore for distributed arc suppression coils in the grid an overcompensation over the complete lenght of the lines has to be taken into account, see Figure 27. The grade of overcompensation in the substation is not constant over the line but decreases with increasing distance from the substation because of the I_{CE} of the line.

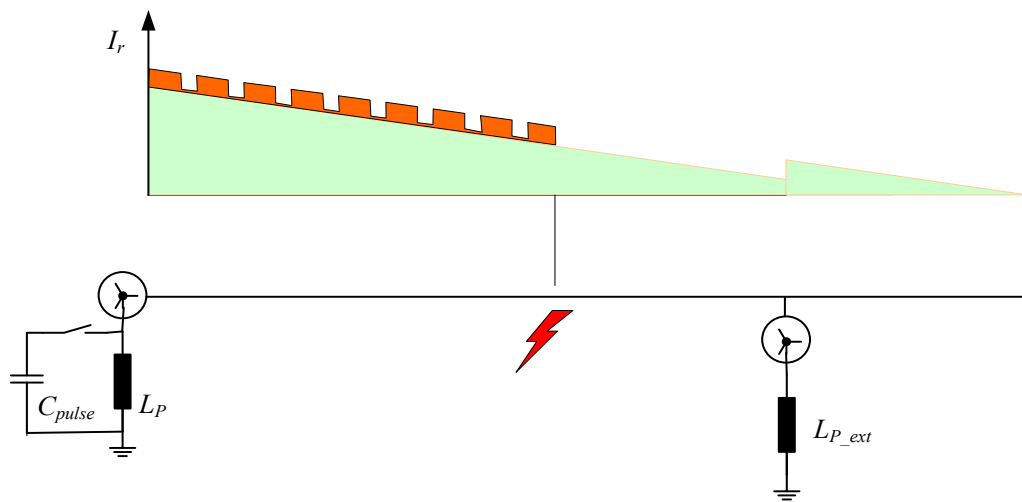

Figure 27: Classic pulse detection relay – Overcompensation requirements with and without distributed arc suppression coils in the grid

The **pulse detection algorithm of EOR-1DS** by contrast evaluates not only the amplitude of the current but also the phase information of the currents. Therefore the faulty feeder can be detected correctly both with unsymmetrical and with symmetrical pulse. Furthermore there is no strict need for overcompensation as shown in Figure 27. This means that the pulse detection of the EOR-1DS is independent from the detuning of the arc suppression coil and also from distance depending detuning of the line, see Figure 28.

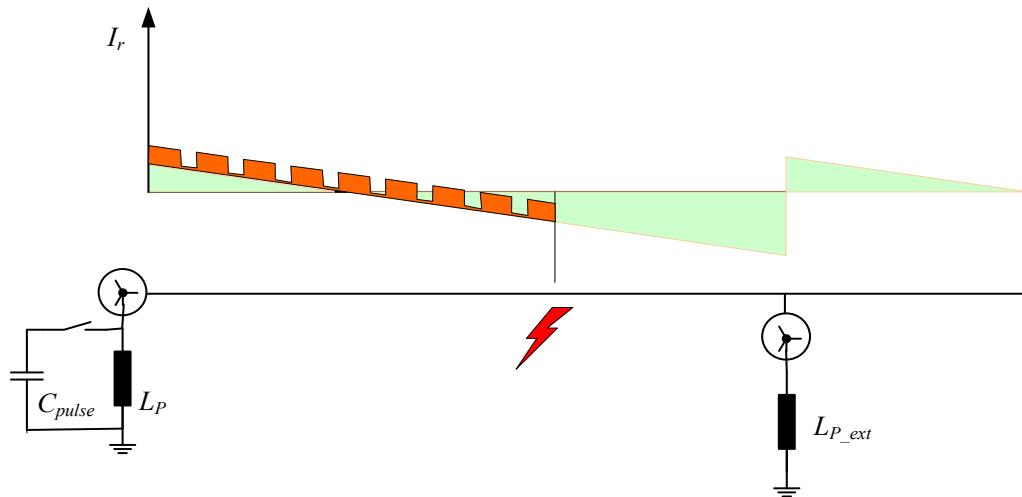

Figure 28: Pulse detection algorithm of the EOR-1DS – no overcompensation requirement with and without distributed arc suppression coils in the grid

Minimum current amplitude

Submenu [Start page → main menu → settings → earth fault → pulse location → min cur. ampli.]

Description This parameter sets the minimal current amplitude of the pulsed signal. The active and reactive current are calculated automatically to determine the value of ΔI_c .



The mean value of the current is made over 5 periods. The minimum and maximum values for plug-on current transducers depend on the chosen current transmission kni.

Shortcut	Min. value	Max. value	Step size	Default	Unit
Min cur. ampli.	OFF or 1	100	1	OFF	A

Setting pulse

Submenu [Start page → main menu → settings → earth fault → pulse location → setting pulse]

Description: The earth fault indicator first asks for the switch on time and then automatically the switch off time. By pushing the push/turn button the selected value is saved. For a correct parameterization of the pulse location method the sum of “swi. on time” and “swi. off time” has to be equal to the sum of switching on and off time of the pulse device (pulse source). Thereby it is not important whether the parameter “swi. on time” or “swi. off time” corresponds to the real switch on time of the pulse device, because an increase of the current (switching on a capacitance in an undercompensated network or switching on an inductance in an overcompensated network) as well as a decrease of the current (switching on a capacitance in an overcompensated network or switching on an inductance in an undercompensated network) gets interpreted from the algorithm as “pulse on”. Hereby accidentally wrong setups by mixing up the “swi. on time” and “swi. off time” are automatically prevented.

Example:
 Unsymmetrical pulse: 1,5 s to 1 s = $\Sigma 2,5s$
 Symmetrical pulse: 1,25s to 1,25s = $\Sigma 2,5s$



The parameterisation for the last case must be set to 1,3s to 1,2s.

Shortcut	Min. value	Max. value	Step size	Default	Unit
Swi. on time	500	2000	100	1000	ms
Swi. off time	500	2000	100	1500	ms

Pulse quota

Submenu [Start page → main menu → settings → earth fault → pulse location → Pulse quota]

Description: The parameter pulse quota defines how many pulses have to be recognized in a pulse sequence.
 Example: 3 form 5. This means that a pulse sequence of 5 x (switch on time + switch off time) is checked and at least 3 pulses have to be recognized correctly. First it is asked in the settings for the total amount of pulses, second for the minimum amount of correct recognized pulses.

Shortcut	Min. value	Max. value	Step size	Default	Unit
Pulse sequence	1	10	1	5	-
Min. of correct recognized pulses	1	10	1	3	-

Reset time pulse detection

Submenu	[Start page → main menu → settings → earth fault → pulse location → reset-time pulse]				
Description	Time for the automatic reset of the pulse detection indication.				
Shortcut	Min. value	Max. value	Step size	Default	Unit
Resetime pulse	5 s	18 h	1 s	15 s	HH:MM:SS

9.2.4 Remote indication

9.2.4.1 Relay function

Relay 1 - Relay 4

Submenu	[Start page → main menu → settings → remote ind. → relay function → relay 1 - relay 4 → function]
Description	<p>The earth fault indicator EOR-1DS has four relays, each of them can be assigned with a different function. The menu leads the user through the different settings by asking the needed parameters. The chosen functions are logically connected with an “OR”.</p> <p>The parameter “wipe time” is only visible when “wipe contact” is chosen for the specific relay and can be used to parametrize a defined time for the relay signal.</p>
Shortcut	Options
Relay 1 - 4	<ul style="list-style-type: none"> ● >Uearth permanent earth fault (PE) ● >Uearth ● Transient PE towards busbar ↑ ● Transient PE towards line ↓ ● Transient towards busbar ↑ ● Transient towards line ↓ ● Short circuit towards busbar ↑ ● Short circuit towards line ↓ ● Short circuit undirected ↓↑ ● Reserved (not choosable) ● Reserved (not choosable) ● pulse detection ● Short circuit to earth towards busbar ↑ ● Short circuit to earth towards line ↓ ● Short circuit to earth undirected ↓↑ ● U_off (on all conductors) ● U_off (on one or more conductors) ● Reserved (not choosable) ● sin(phi) ↑ ● sin(phi) ↓ ● cos(phi) ↑ ● cos(phi) ↓ ● cos(phi) ↓↑
Default	● No function set

Contact type

Submenu [Start page → main menu → settings → remote ind. → relay function → relay 1 - relay 4 → contact type]

Description Here the contact type for relay 1-4 is chosen.

Permanent contact: By the contact type permanent contact the relays are switched on, until the reset.

Wipe contact: By the contact type wipe contact the relays switch on for a defined time from the occurrence of the event and after that the relays switch off again. The wipe time can be parametrized in the menu directly after wipe contact was chosen for the specific relay.

Immediate mode: In immediate mode the relays switch on after a delay of 30 ms to 60 ms and is activated as long as the event occurs. After the event the relays switch off immediately. (<100 ms)

Shortcut	Options	Default
Contact type relay 1 - 4	<ul style="list-style-type: none"> ● permanent contact ● wipe contact ● immediate 	● Permanent contact

Status function (available only for relay 1)

Submenu [Start page → main menu → settings → remote ind. → relay function → relay 1 → status function]

Description Relay 1 can alternatively be set fix as status relay / life contact. I.e. if 'status relay' is chosen the assignment of other relay function is disabled.

Shortcut	Options	Default
Status function	<ul style="list-style-type: none"> ● normal function ● status relay 	● Status relay

NO / NC

Submenu [Start page → main menu → settings → remote ind. → relay function → relay 1 - relay 4 → NO / NC]

Description In this menu it is possible to choose "normally open" (NO) or "Normally closed" (NC) for each relay.

Shortcut	Options	Default
Status function	<ul style="list-style-type: none"> ● NO ● NC 	● NO

9.2.5 Modbus RS485

Address

Submenu	[Start page → main menu → settings → remote ind. → Modbus RS485 → address]				
Description	Slave address of the EOR-1DS in Modbus RS485 protocol.				
Shortcut	Min. value	Max. value	Step size	Default	Unit
MODBUS address	1	247	1	1	-

Baud rate

Submenu	[Start page → main menu → settings → remote ind. → Modbus RS485 → baud rate]				
Description	Transmission rate of the Modbus RS485 interface.				
Shortcut	Value	Default	Unit		
MODBUS baud rate	<input type="radio"/> 9600	<input type="radio"/> 19200	Baud		
	<input type="radio"/> 19200				
	<input type="radio"/> 38400				

Parity bit

Submenu	[Start page → main menu → settings → remote ind. → Modbus RS485 → parity bit]				
Description	Parity bit of the Modbus RS485 interface.				
Shortcut	Value	Default			
Parity bit	<input type="radio"/> none (2 stop bits)	<input type="radio"/> Even			
	<input type="radio"/> even (1 stop bit)				
	<input type="radio"/> odd (1 stop bit)				

Register mapping

Submenu	[Start page → main menu → settings → remote ind. → Modbus RS485 → Reg. mapping]				
Description	Selection of different register mapping (data point lists), also see chapter 10.3 and 10.4.				
Shortcut	Value	Default			
Register mapping	<input type="radio"/> Standard	<input type="radio"/> Standard			
	<input type="radio"/> SNH 1.7				

Modbus mode

Submenu [Start page → main menu → settings → remote ind. → Modbus RS485 → modbus mode]

Description In the 'delayed off' mode the Modbus interface is put into sleep mode after a configured time between 20 s to 600 s when the supply voltage is lost. As soon as the supply voltage is available again the Modbus interface is activated.
Permanent off deactivates the Modbus interface permanently.



Only one mode can be active at once.

Shortcut	Value	Default
Modbus mode	<ul style="list-style-type: none"> ● Perm. off ● Delayed off (20 .. 600 s) ● Debug mode 	Delayed off (30 s)

Debug mode

Submenu [Start page → main menu → settings → remote ind. → Modbus RS485 → modbus mode → Debug mode]

Description The logbook entries, which are normally written on the SD-card, can be alternatively sent online via the RS485 interface. A Modbus RS485 communication is not possible when the debug mode is activated. The communication parameters of the RS485 port in debug mode comply with the chosen Modbus settings.



The debug mode will be disabled after 3 hours automatically.

Shortcut	Value	Default
Debug mode	ON/OFF	OFF

9.2.6 Voltage Measurement

For detection of power flow direction and fault direction the device can be connected to LRM system or a sensor for voltage measurement, see also chapter 7.5.



The EOR-1DS does not provide a second capacity for measurement of the voltage on a capacitive voltage divider. An appropriate device has to be used that provides a capacity corresponding to the capacitive voltage divider (e.g. Capdis or WEGA system). The EOR-1DS can only be connected in parallel to such a device with a LRM – adapter cable.



When the voltage measurement is activated a voltage measurement must be connected. If no voltage measurement is connected while the function is activated this may cause deviations in the current measurement. In addition the red LED of the EOR-1DS is blinking, in case of no voltage is being measured and the EOR-1DS has power supply.

Voltage measurement activation

Submenu	[Start page → main menu → settings → voltage → voltage on/off]		
Description	When the voltage measurement is activated, the direction of the current flow will be shown with a sign in the main menu. Also the directed short circuit and the qu2 transient method are shown in the settings menu and can be used.		
Shortcut	Value	Default	
Volt. over LRM	ON/OFF	ON	

Rated voltage

Submenu	[Start page → main menu → settings → volateg → settings → rated voltage]				
Description	The rated voltage (phase - phase) is shown on the overview page of the voltage and is used for the adjustment of the conductors L1/L2/L3 as reference value.				
Shortcut	Min. value	Max. value	Step size	Default	Unit
Rated volt. P-P	0.4	36	0.1	20	kV



The voltage adjustment is only for LRM measurement.

Voltage record adjustment

Submenu [Start page → main menu → settings → voltage → settings → adj. voltage Lx]

Description To measure the phase voltage with the EOR-1DS as exact as possible, all phase voltages can be calibrated separately. For this process a voltage must be applied on the LRM socket. Then it is possible to adjust on every conductor the present primary voltage which is measured with a reference device.

Shortcut	Min. value	Max. value	Step size	Default	Unit
Adj. voltage L1/L2/L3	0.5	36	0.1	11.5	kV

Threshold voltage detection

Submenu [Start page → main menu → settings → volateg → threshold U_off]

Description This function detects a missing voltage if the voltage is below the threshold. The signal is made for all or any phase.

Shortcut	Min. value	Max. value	Step size	Default	Unit
Rated volt. P-P	0.4	36	0.1	20	kV

9.3 Test and reset



When the voltage measurement is deactivated, only a unidirectional short circuit or earth fault can be tested.

9.3.1 Short circuit test

Test function short circuit undirected

Submenu [Start page → main menu → test/reset → short cir. test → test direct. ↑↓]

Description With this menu the fault indication can be simulated. An undirected short circuit on all three is signalled.

Test function short circuit backward

Submenu [Start page → main menu → test/reset → short cir. test → test direct. ↑]

Description With this menu the fault indication can be simulated. A short circuit on all three phases in reverse direction and an undirected short circuit are signalled.

Test function short circuit forward

Submenu [Start page → main menu → test/reset → short cir. test → test direct. ↓]

Description With this menu the fault indication can be simulated. A short circuit on all three phases in forward direction and an undirected short circuit are signalled.

9.3.2 Earth fault test



In the “earth fault test” menu all phases or only one phases is selected for the fault indication.

Test function earth fault undirected

Submenu [Start page → main menu → test/reset → earth fault test → L1, L2 and L3 / Lx → test direct. ↑↓]

Description With this menu the fault indication can be simulated. An undirected earth fault on all selected phases is signalled. The indications >Ue and permanent earth fault are not simulated.

Test function earth fault backward

Submenu [Start page → main menu → test/reset → earth fault test → L1, L2 and L3 / Lx → test direct. ↑]

Description With this menu the fault indication can be simulated. An earth fault on all selected phases in backward direction and an undirected earth fault are signalled. The indications >Ue and permanent earth fault are not simulated.

Test function earth fault forward

Submenu [Start page → main menu → test/reset → earth fault test → L1, L2 and L3 / Lx → test direct. ↓]

Description With this menu the fault indication can be simulated. An earth fault on all selected phases in forward direction and an undirected earth fault are signalled. The indications >Ue and permanent earth fault are not simulated.

Reset function

Submenu [Start page → main menu → test/reset → reset]

Description When a fault is displayed, it is possible to reset the indication with this menu step. Alternatively the fault display can be reset via Modbus, the binary input 'reset' or the corresponding reset time.

CT log at test

Submenu [Start page → main menu → test/reset → CT log at test]

Description In this menu it can be selected whether a Comtrade log is created for simulated fault indications or not.

Self test

Submenu [Start page → main menu → test/reset → Self test]

Description The device performs a self test.

9.3.3 Binary input

The EOR-1DS has two binary inputs with fixed functions. The binary input "reset" perform a reset of all active fault signals of the device. The binary input "test" has currently no function.

To use the binary inputs a switch needs to be installed between the root and the binary input.



The binary inputs may only be used potential-free.

9.4 System

9.4.1 General

Info/factory reset

Submenu [Start page → main menu → system → info/fac. reset]

Description This menu shows information about the hardware version, firmware version and the production date.
By pushing the button for 5 s in this menu the device is reset to factory settings.



When a factory reset is performed also the chosen current transformer type is reset to "SR55". If the plug-on current transducer is used, the transformer ratio knob afterwards also has to be set again.

Language

Submenu [Start page → main menu → system → language]

Description In this menu the display language can be changed. Depending on the firmware version there are different languages available.

Shortcut	Value	Default
language	<input checked="" type="radio"/> Deutsch	<input checked="" type="radio"/> English
	<input type="radio"/> English	

9.4.2 Date and time

Time

Submenu [Start page → main menu → system → date/time → change time]

Description In this menu the time is set and saved in the real-time clock. It always uses the 24h format. The time is used in the Comtrade and log function.



There is no change between summer and winter time (DST).

Shortcut	Min. value	Max. value	Step size	Unit
hours	0	23	1	hours
minutes	0	59	1	minutes
seconds	0	59	1	seconds

Date

Submenu [Start page → main menu → system → date/time → date]

Description In this menu the date is set and saved in the real-time clock. First the month is set, then the day and the year. The date is used in the Comtrade and log function.

Shortcut	Min. value	Max. value	Step size	Unit
month	1	12	1	month
day	1	28,30,31	1	day
year	[20]00	[20]99	1	year

9.4.3 Other settings

9.4.3.1 Settings code

Change settings code

Submenu [Start page → main menu → system → other settings → settings code]

Description All settings are protected against accidental changes by the settings code. This code can be changed at the device. **The device is delivered with the code '111'.**



The new code must be confirmed with a second input.

Shortcut	Min. value	Max. value	Step size	Default
Code	0	999	1	111

9.4.3.2 Display configuration

OLED time out

Submenu [Start page → main menu → system → other settings → Display config → OLED time out]

Description After this time the display is turned off.

Shortcut	Min. value	Max. value	Step size	Default	Unit
Contrast	20	300	10	30	s

Brightness

Submenu [Start page → main menu → system → other settings → Display config → brightness]

Description If the visibility of the display is not optimal, the Brightness can be adapted here.

Demomode

Submenu [Start page → main menu → system → other settings → Display config → Demomode]

Description In the demomode the display is continuously activated and measurement values are simulated in the display.



ATTENTION! No indication during demomode. When using too long the OLED-display can burn-in.

9.4.3.3 I/O configuration

Phase current transformer

Submenu [Start page → main menu → system → other settings → I/O config → current CT → phase current]

Description With this parameter the used current transformer is chosen. For the plug-on current transducer the transformer ratio kni (ratio between primary and secondary side, definition range 1 .. 2500) has to be set in the next step according to the used current transformer. For a kni of 1 the measured values are shown as secondary values in mA. For low power sensors instead of the transformer ratio kni the primary and secondary values must be set.



Only with clip on CT and low power sensors the sum current 3I0 can be measured.

Shortcut	Value	Default
ct selection	<ul style="list-style-type: none"> ● SR55 ● clip on CT ● low power 	<ul style="list-style-type: none"> ● SR55

Sum current

Submenu [Start page → main menu → system → other settings → I/O config → current CT → sum current]

Description With this parameter it is selected if the sum current is measured or calculated. For the sum current the same transformer as the phase current is selected. If measured is selected, depending on the transformer the kni (definition range 1 .. 1200) or primary and secondary values must be set.

Shortcut	Value	Default
ct selection	<ul style="list-style-type: none"> ● calculated ● measured 	<ul style="list-style-type: none"> ● calculated

Voltage input

Submenu [Start page → main menu → system → other settings → I/O config → voltage input]

Description With this parameter the voltage measurement can be selected. For low power measurement the primary and secondary values and for U10 the knu must be set.

Shortcut	Value	Default
ct selection	<ul style="list-style-type: none"> ● LRM ● Low power ● U10 	<ul style="list-style-type: none"> ● LRM

We take care of it.

Blinking lamp

Submenu [Start page → main menu → system → other settings → I/O config → blinking lamp]

Description If a blinking lamp is connected to the EOR-1DS, the right type must be selected.

Shortcut	Value	Default
Blinking lamp	<ul style="list-style-type: none">● type BL4.1/BL6● type BL7	<ul style="list-style-type: none">● type BL4.1/BL6

9.4.4 Operating manual

Manual

Submenu [Start page → main menu → system → manual]

Description By clicking on this submenu a QR-code is visualized on the display. By scanning the QR-code a link to the latest version of the operating manual for the device is opened.

9.5 Switch display off

Display off

Submenu [Start page → main menu → display off]

Description By clicking on this menu the display is switched off. All other functions of the device are unaffected. The display gets active again when the button is pushed again.

9.6 SD card

CAUTION! For the change of the SD card please take care of the installation and commissioning notes in chapter 7.6.



The SD card function is only available when a power supply is connected and not in the backup capacitor operation.

9.6.1 Files on the SD card

When the device is used with a SD card, there are different files saved on the SD card. They are explained in the following.









Name	Änderungsdatum	Typ	Größe
 EOR00001.CFG	13.09.2023 00:10	Comtrade File	2 KB
 EOR00001.DAT	13.09.2023 00:10	DAT-Datei	43 KB
 EOR00002.CFG	13.09.2023 00:11	Comtrade File	2 KB
 EOR00002.DAT	13.09.2023 00:11	DAT-Datei	42 KB
 EOR-CT.SYS	13.09.2023 00:10	Systemdatei	1 KB
 EOR-LOG.txt	13.09.2023 00:11	Textdokument	2 KB
 firmware.hex	16.08.2023 13:27	HEX-Datei	1.282 KB
 update.sys	13.09.2023 00:10	Systemdatei	1 KB

Figure 29: Files on the SD card

Type of file	Function
firmware.hex	Firmware for firmware updates (version is included in the file header)
EOR-LOG.txt	log file in .txt file format
EORxxxx.CFG	Comtrade file
EORxxxx.DAT	saved measurement values
update.sys	Internal file to leave the bootloader after firmware update
EOR_CT.SYS	Counter for numbering the comtrades



The log includes parameter changes, fault indications and the state of the relays with date and time stamps. For each fault indication the associated comtrade index is specified. Also, a daily heartbeat at 09:00 am with hardware and firmware version as well as an entry after every reboot with the according reason is saved.

9.6.2 Copy and save parameter configuration on the SD card

Load parameter configuration from SD card to EOR-1DS

Submenu	[Start page → main menu → SD card → „Conf. SD --> EOR“]
Description	<p>To make a fast and safe configuration possible, the EOR-1DS can copy all settings on a SD card. This configuration can be read in by any other EOR-1DS. When saving a number from 0 to 9 is chosen for the configuration. With this function it is possible to save several configurations on one SD card. To load a configuration the according number must be selected.</p> <p>By choosing this menu point the current parameterization from the SD card is read into the device.</p>

Write parameter configuration of EOR-1DS to SD card

Submenu	[Start page → main menu → SD card → „Conf. EOR --> SD“]
Description	<p>To make a fast and safe configuration possible, the EOR-1DS can copy all settings on a SD card. This configuration can be read in by other EOR-1DS. When saving a number from 0 to 9 is chosen for the configuration. With this function it is possible to save several configurations on one SD card. To load a configuration the according number must be selected.</p> <p>By choosing this menu point the current parameterization is written onto the SD card from the device.</p>

9.6.3 Save fault record on a SD card in Comtrade format

Pretrigger

Submenu	[Start page → main menu → SD card → COMTRADE Log → Pretrigger]				
Description	The pretrigger sets the time recorded before the trigger point.				
Shortcut	Min. value	Max. value	Step size	Default	Unit
contrast	OFF or 100	1000	100	100	ms

Posttrigger

Submenu	[Start page → main menu → SD card → COMTRADE Log → Posttrigger]				
Description	Determinates the length of the Comtrade after the trigger point.				
Shortcut	Min. value	Max. value	Step size	Default	Unit
contrast	OFF or 100	3000	100	2000	ms

Comtrade Log

Submenu	[Start page → main menu → SD card → COMTRADE Log]
Description	When a fault is detected a Comtrade log is written on the SD card. With this function a fault record is created on the SD card when the push/turn button is pushed.

9.6.4 Firmware update with SD card

NOTICE!

Undefined firmware state!

When the power supply is interrupted during a firmware update an undefined firmware state occurs and the device must be send in for repair.

- ➡ Make sure that during a firmware update the power supply is not interrupted.

NOTICE!

Existing parameter file on SD card will be overwritten during firmware update!

During a firmware update a pre-existing parameter file on the SD card will be overwritten with the current parameter setup at the time of the firmware update.

- ➡ Use two SD cards for the firmware update file and a customer specific parameter file.

Firmware update

Submenu	[Start page → main menu → SD card → FW update]
Description	With an SD card the firmware of the device can be updated. For this process it is necessary to copy the new firmware (firmware.hex) in the root directory of the SD card. In the menu point 'FW update' the current and new firmware version are shown. To perform a firmware update the operation button must be pressed for 5 seconds in the 'FW update' menu. A counter shows the remaining time to press the button. The display turns off and the red and green LEDs start to blink. After a successful update the device restarts automatically. During the firmware update the parameters remain unchanged and are not reset.

10. Modbus protocol

The EOR-1DS offers a serial Modbus interface, which can be also used for parameterizing the device.

10.1 Modbus mode



The different Modbus modes are explained in chapter 9.2.5.

10.2 Technical data Modbus interface

Subject	Description
Type	<ul style="list-style-type: none">● Two wire RS485 connection● Modbus RTU mode
Baud rate	<ul style="list-style-type: none">● 9600● 19200● 38400
Mode	<ul style="list-style-type: none">● 1 start / 8 bits / even parity / 1 stop: total 11 bits● 1 start / 8 bits / odd parity / 1 stop: total 11 bits● 1 start / 8 bits / none parity / 2 stop: total 11 bits
Address range	<ul style="list-style-type: none">● 1 to 247
Function	<ul style="list-style-type: none">● Function 03 (0x03): read register● Function 06 (0x06): write register● Function 08 (0x08): diagnosis (only echo)
Byte structure	<ul style="list-style-type: none">● HI-Byte: 0bX15X14X13X12X11X10X09X08● LO-Byte: 0bX07X06X05X04X03X02X01X00● reserved bits are reported back with '0'

10.3 datapoint list - register mapping – ‘Standard’

Register		R/W	Unit	Values	Description	From firm-ware Version
dec	hex					
Trip value configuration (Register 1 to 100)						
1	0x0001	R/W	A	20 to 2500* Step: 10 0 = OFF	Short-circuit: Trip current *Rogowski coil; with plug-on current transformer depending on kni	1.21
2	0x0002	R/W	A	40 to 500* 0 = OFF	Short-circuit to earth: Trip current *Rogowski coil; with plug-on current transformer depending on kni	1.21
9	0x0009	R/W	ms	20 to 3000 Step: 20	Short-circuit: response time	1.21
10	0x000A	R/W	ms	20 to 1000	Short-circuit to earth: response time	1.21
13	0x000D	R/W	A	0 to 30* 0 = OFF	Pulse locating: Minimum current deviation *Rogowski coil; with plug-on current transformer depending on kni	1.21
14	0x000E	R/W	ms	500 to 2000 Step: 100	Pulse method: Switch on time of the detuning	1.21
15	0x000F	R/W	ms	500 to 2000 Step: 100	Pulse method: Switch off time of the detuning	1.21
16	0x0010	R/W		1 to 10	Pulse method: Pulse window (observation window)	1.21
17	0x0011	R/W		1 to 10	Pulse method: Minimum successfully detected pulses in observation window	1.21
18	0x0012	R/W	ON/OFF	0 or 1	Voltage detection by LRM interface	1.21
19	0x0013	R/W	ON/OFF	0 or 1	Directional fault indication (earth-fault and short-circuit)	1.21
22	0x0016	R/W	A	20 to 2500* Step: 10 0 = OFF	>>I short-circuit: trip current *Rogowski coil; with plug-on current transformer depending on kni	2.04
23	0x0017	R/W	ms	20 to 3000 Step: 20	>>I short-circuit: response time	2.04
24	0x0018	R/W	A	40 to 500* Step: 10 0 = OFF	>>Ie short-circuit to earth: trip current *Rogowski coil; with plug-on current transformer depending on kni	2.04
25	0x0019	R/W	ms	20 to 3000 Step: 20	>>Ie short-circuit to earth: response time	2.04
32	0x0020	R/W	A	1 to 100 * 0 = OFF	Transient detection (qu2): Current trip value $I_{CE,min}$ *Rogowski coil; with plug-on current transformer depending on kni	1.21
33	0x0021	R/W	%	1 to 90	Transient detection (qu2): Voltage trip value >U _e	1.21
34	0x0022	R/W	ON/OFF	0 or 1	Transient detection (qu2): Direction filter	1.21

35	0x0023	R/W	ON/ OFF	0 or 1	Transient detection (qu2): Retrigger ability	1.21
36	0x0024	R/W	ms	0 to 60 0 = OFF	Transient detection (qu2): Permanent Earth-fault	1.21
37	0x0025	R/W		0 to 360 0 = OFF	Transient detection (qu2): Rot./Grad.	1.21
40	0x0028	R/W	V	500 to 36000 Step: 100	Rated voltage (phase-phase)	1.21
45	0x002D	R/W	%	20 % to 90 % Step: 10 0 = OFF	U _{off} voltage detection threshold level	2.04
50	0x0032	R/W	°	0° to 90° Step: 1°	sin(phi) detection: minimum angle	2.04
51	0x0033	R/W		0 to 10 Step: 1	sin(phi) detection: cycles (20 ms) in same direction	2.04
52	0x0034	R/W	A	0 to 150 Step: 1 0 = OFF	sin(phi) detection: I _b min	2.04
60	0x003C	R/W	°	0° to 90° Step: 1°	cos(phi) detection: minimum angle	2.04
61	0x003D	R/W		0 to 10 Step: 1	cos(phi) detection: cycles (20 ms) in same direction	2.04
62	0x003E	R/W	A	0 to 1000 Step: 1 0 = OFF	cos(phi) detection: I _w min	2.04
63	0x003F	R/W	ON/ OFF	0 or 1	Cos(phi) mom-directional indication	2.04
Reset configuration (Registers 101 to 200)						
102	0x0066	R/W	A	2 to 50 2 = OFF	Reset by recovering operating current on conductor L1	1.21
106	0x006A	R/W	s	5 to 64799	Short-circuit: reset time	1.21
107	0x006B	R/W	s	5 to 64799	Earth-fault: reset time	1.21
108	0x006C	R/W	s	5 to 64799	Earth-fault: reset time Pulse location	1.21
110	0x006E	R/W	s	5 to 64799	Earth-fault: reset time transient detection	1.21
111	0x006F	R/W	s	5 to 64799	>U earth detection: reset time	1.21
112	0x0070	R/W	s	5 to 64799	Short-circuit to earth: reset time	1.21
113	0x0071	R/W	s	5 to 64799	sin(phi) detection: reset time	2.04
114	0x0072	R/W	s	5 to 64799	cos(phi) detection: reset time	2.04
Indicator status (Register 201 to 300)						
201	0x00C9	R	%	0 to 100	Capacitor charge	1.21

203	0x00CB	R	-	0 to 65535	Indicator status summary 1: X ₀₀ = short-circuit (1=yes / 0=no) X ₀₁ = short-circuit phase 1 (1=yes / 0=no) X ₀₂ = short-circuit phase 2 (1=yes / 0=no) X ₀₃ = short-circuit phase 3 (1=yes / 0=no) X ₀₄ = earth-fault (1=yes / 0=no) X ₀₅ = earth-fault phase 1 (1=yes / 0=no) X ₀₆ = earth-fault phase 2 (1=yes / 0=no) X ₀₇ = earth-fault phase 3 (1=yes / 0=no) X ₀₈ = >I _E fault any phase (1=yes / 0=no) X ₀₉ = reserved X ₁₀ = external power supply (1=yes / 0=no) X ₁₁ to X ₁₄ = reserved X ₁₅ = mode (1=indicating / 0=standby)	1.21
204	0x00CC	R/W	-	0 or 1	Set indicator into operating or test mode: 0 = set indicator into operating mode 1 = test indicator / set indicator into test mode	1.21
206	0x00CE	R	-	10 or 65535	Firmware Version of indicator	1.21
221	0x00DD	R	-	0 to 15	Short-circuit fault status and direction on conductor 1: X ₀₀ = fault current detected, direction unknown (1=yes / 0=no) X ₀₁ = fault current in bus bar direction detected (1=yes / 0=no) X ₀₂ = fault current in cable direction detected (1=yes / 0=no) X ₀₃ = second short-circuit detected (within reset time) (1=yes / 0=no)	1.21
222	0x00DE	R	-	0 to 15	Short-circuit fault status and direction on conductor 2 <i>analogous to register 221</i>	1.21
223	0x00DF	R	-	0 to 15	Short-circuit fault status and direction on conductor 3 <i>analogous to register 221</i>	1.21
224	0x00E0	R	-	0 to 15	Earth-fault status and direction on conductor 1 X ₀₀ = fault detected, direction unknown X ₀₁ = fault in busbar direction detected X ₀₂ = fault in cable direction detected X ₀₃ bis X ₀₇ = reserved X ₀₈ = detection by pulse method X ₀₉ = reserved X ₁₀ = detection by transient method X ₁₁ = detection by transient method PE	1.21
225	0x00E1	R	-	0 to 15	Earth-fault status and direction on conductor 2 <i>analogous to register 224</i>	1.21
226	0x00E2	R	-	0 to 15	Earth-fault status and direction on conductor 3 <i>analogous to register 224</i>	1.21

227	0x00E3	R		0 to 65535	Earth-fault fault status and direction of all conductors: X ₀₀ = fault detected, direction unknown X ₀₁ = fault in bus bar direction detected X ₀₂ = fault in cable direction detected X ₀₃ = reserved X ₀₈ = pulse detection X ₀₉ = reserved X ₁₀ = transient detection X ₁₁ = transient detection (permanent fault) X ₁₂ = >U _e X ₁₃ = >U _e (permanent earth fault)	1.21
228	0x00E4	R	-	0 to 65535	>I _E fault status and direction of all conductors: X ₀₀ = fault detected, direction unknown X ₀₁ = fault in bus bar direction detected X ₀₂ = fault in cable direction detected	1.21
230	0x00E6	R	°	+/- 180	Angle between voltage and current L1	1.21
231	0x00E7	R	°	+/- 180	Angle between voltage and current L2	1.21
232	0x00E8	R	°	+/- 180	Angle between voltage and current L3	1.21
233	0x00E9	R	°	+/- 180	Angle between voltage U ₀ and current I ₀	1.21
234	0x00EA	R		+/- 100	cos(phi) phase L1; value is multiplied by 100	2.04
235	0x00EB	R		+/- 100	cos(phi) phase L2; value is multiplied by 100	2.04
236	0x00EC	R		+/- 100	cos(phi) phase L3; value is multiplied by 100	2.04
237	0x00ED	R		+/- 100	cos(phi) U ₀ and I ₀ ; value is multiplied by 100	2.04
238	0x00EE	R		0 or 1	Phase rotation: 0 = not L1 – L2 – L3 1 = L1 – L2 – L3	2.04
239	0x00EF	R		0 or 1	Phase rotation: 0 = not L1 – L3 – L2 1 = L1 – L3 – L2	2.04
240	0x00F0	R	V	0 to 65535	Voltage level L1	1.21
241	0x00F1	R	V	0 to 65535	Voltage level L2	1.21
242	0x00F2	R	V	0 to 65535	Voltage level L3	1.21
243	0x00F3	R	V	0 to 65535	Zero-Sequence Voltage U ₀	1.21
245	0x00F5	R	A	int*	Current Phase L1	1.21
246	0x00F6	R	A	int*	Current Phase L2	1.21
247	0x00F7	R	A	int*	Current Phase L3	1.21
248	0x00F8	R	A	int*	Current I ₀	1.21
					*Values are displayed in the two's complement	
250	0x00FA	W	-	0 or 1	Reset indicator into standby mode: 0 = no change 1 = Reset After reset, the register will be cleared automatically	1.21

251	0x00FB	W	-	0 or 1	<p>Set indicator into testing mode: 0 = no change 1 = Set indicator to testing mode After switching to operating mode, the register will be cleared automatically X₀₀ = set all activated fault detection methods in cable direction* X₀₁ = set short circuit in bus bar direction* X₀₂ = set short circuit in cable direction* X₀₃ = set earth fault in bus bar direction* X₀₄ = set earth fault cable direction* X₀₅ to X₁₅ = reserved *Note: undirected fault simulation, if voltage detection is switched off.</p>	1.21
255	0x00FF	R		0 to 7	<p>Voltage below U_{off} threshold level 0 = all voltages over the threshold X₀₀ = U_{L1} below threshold X₀₁ = U_{L2} below threshold X₀₂ = U_{L3} below threshold</p>	2.04
260 261	0x0104 0x0105	R	MW	float32	Active power P	1.21
262 263	0x0106 0x0107	R	MW	float32	Reactive power Q	1.21
264 265	0x0108 0x0109	R	MW	float32	Apparent power S	1.21
266 267	0x010A 0x010B	R	MW	float32	Active power P L1	1.21
268 269	0x010C 0x010D	R	MW	float32	Active power P L2	1.21
270 271	0x010E 0x010F	R	MW	float32	Active power P L3	1.21
272 273	0x0110 0x0111	R	MW	float32	Active power P L0	1.21
274 275	0x0112 0x0113	R	MW	float32	Reactive power Q L1	1.21
276 277	0x0114 0x0115	R	MW	float32	Reactive power Q L2	1.21
278 279	0x0116 0x0117	R	MW	float32	Reactive power Q L3	1.21
280 281	0x0118 0x0119	R	MW	float32	Reactive power Q L0	1.21
282 283	0x011A 0x011B	R	MW	float32	Apparent power S L1	1.21
284 285	0x011C 0x011D	R	MW	float32	Apparent power S L2	1.21
286 287	0x011E 0x011F	R	MW	float32	Apparent power S L3	1.21
288 289	0x0120 0x0121	R	MW	float32	Apparent power S L0	1.21

292	0x0124	R	A	int	Maximum current of last fault on phase 1	1.25
293	0x0125	R	A	int	Maximum current of last fault on phase 2	1.25
294	0x0126	R	A	int	Maximum current of last fault on phase 3	1.25
295	0x0127	R	A	int	Maximum current of last fault on I0	1.25
MODBUS configuration (Register 301 to 419)						
301	0x012D	R/W	-	1 to 247	MODBUS Address	1.21
302	0x012E	R/W	-	0,1 or 2	Parity bit configuration 0 = no parity (two stop bits) (default) 1 = odd parity (one stop bit) 2 = even parity (one stop bit)	1.21
303	0x012F	R/W	bps	9600, 19200, 38400	Baud rate configuration	1.21
304	0x0130	R/W	sec	20 to 600 steps: 10	Modbus delayed off, after external supply fails	1.25
305	0x0131	R/W	-	0 to 2	Modbus mode: 0 = reserved 1 = permanent off (Warning: if set, Modbus needs to be switched on at side) 2 = delayed off	1.25
Energy counter (Register 320 to 349)						
320	0x0140	W		123	Reset all energy counter	2.04
325 326	0x0145 0x0146	R	kWh	uint32	Active power counter (P): cable direction	2.04
327 328	0x0147 0x0148	R	kWh	uint32	Active power counter (P): busbar direction	2.04
329 330	0x0149 0x014A	R	kVar h	uint32	Reactive power counter (Q): cable direction	2.04
331 332	0x014B 0x014C	R	kVar h	uint32	Reactive power counter (Q): busbar direction	2.04
340 341	0x0154 0x0155	R		float32	cos(phi) phase L1	2.04
342 343	0x0156 0x0157	R		float32	cos(phi) phase L2	2.04
344 345	0x0158 0x0159	R		float32	cos(phi) phase L3	2.04
346 347	0x015A 0x015B	R		float32	cos(phi) U ₀ and I ₀	2.04

Comtrade configuration (register 350 to 352)						
350	0x015E	R/W	ms	0 to 1000 steps: 100	Comtrade record: Pretrigger	1.25
351	0x015F	R/W	ms	0 to 3000 steps: 100	Comtrade record: Posttrigger	1.25
352	0x0160	R/W	-	0 or 1	Comtrade record for manual test in the menu 0 = Comtrade record during test 1 = no Comtrade record during test	1.25
MODBUS configuration (Register 420 to 500)						
424	0x01A8	R/W	time	0 to 23	Real time clock: Hours Format: 24h	1.21
425	0x01A9	R/W	time	0 to 59	Real time clock: minutes	1.21
426	0x01AA	R/W	time	0 to 59	Real time clock: seconds	1.21
427	0x01AB	R/W	date	1 to 31	Real time clock: Day (Invalid days, like 31 st of February, will cause unspecific behaviour!)	1.21
428	0x01AC	R/W	date	1 to 12	Real time clock: month	1.21
429	0x01AD	R/W	date	2014 to 2099	Real time clock: year	1.21
450	0x01C2	R/W	-	0 to 32767	Relay 1 function part 1 (part 2 see register 480): X ₀₀ = >Uearth permanent fault (PE) X ₀₁ = >Uearth X ₀₂ = Transient PE towards busbar X ₀₃ = Transient PE towards line X ₀₄ = Transient towards busbar X ₀₅ = Transient towards line X ₀₆ = Short circuit towards busbar X ₀₇ = Short circuit towards line X ₀₈ = Short circuit undirected X ₀₉ = reserved X ₁₀ = reserved X ₁₁ = Pulse detection X ₁₂ = Short-circuit to earth: towards busbar X ₁₃ = Short-circuit to earth: towards line X ₁₄ = Short-circuit to earth: undirected X ₁₅ = reserved	1.21

451	0x01C3	R/W	-	0 to 32767	Relay 2 function part 1 (part 2 see register 481): X ₀₀ = >Uearth permanent fault (PE) X ₀₁ = >Uearth X ₀₂ = Transient PE towards busbar X ₀₃ = Transient PE towards line X ₀₄ = Transient towards busbar X ₀₅ = Transient towards line X ₀₆ = Short circuit towards busbar X ₀₇ = Short circuit towards line X ₀₈ = Short circuit undirected X ₀₉ = reserved X ₁₀ = reserved X ₁₁ = Pulse detection X ₁₂ = Short-circuit to earth: towards busbar X ₁₃ = Short-circuit to earth: towards line X ₁₄ = Short-circuit to earth: undirected X ₁₅ = reserved	1.21
452	0x01C4	R/W	-	1,2 or 4	Relay 1 to 4 contact type (all relay settings are changed in write direction, in read direction only relay 1 is indicated): X ₀₀ = permanent contact X ₀₁ = wipe contact (please refer to register 453) X ₀₂ = immediate mode (resets as soon as fault current stops) X ₀₃ to X ₁₅ = reserved	1.21
453	0x01C5	R/W	ms	20 to 500 Step: 10	Relay 1 wipe time	1.21
454	0x01C6	R/W	ms	20 to 500 Step: 10	Relay 2 wipe time	1.21
455	0x01C7	R/W	-	1,2 or 4	Relay 1 contact type: <i>analogous to register 452</i>	1.21
456	0x01C8	R/W	-	1,2 or 4	Relay 2 contact type: <i>analogous to register 452</i>	1.21
460	0x01CC	-	-	-	<i>Please refer to register 20</i>	1.21
461	0x01CD	-	-	-	<i>Please refer to register 21</i>	1.21

470	0x01D6	R/W	-	0 bis 32767	Relay 3 function part 1 (part 2 see register 482): X ₀₀ = >Uearth permanent fault (PE) X ₀₁ = >Uearth X ₀₂ = Transient PE towards busbar X ₀₃ = Transient PE towards line X ₀₄ = Transient towards busbar X ₀₅ = Transient towards line X ₀₆ = Short circuit towards busbar X ₀₇ = Short circuit towards line X ₀₈ = Short circuit undirected X ₀₉ = reserved X ₁₀ = reserved X ₁₁ = Pulse detection X ₁₂ = Short-circuit to earth: towards busbar X ₁₃ = Short-circuit to earth: towards line X ₁₄ = Short-circuit to earth: undirected X ₁₅ =reserved	1.21
471	0x01D7	R/W	-	0 bis 32767	Relay 4 function part 1 (part 2 see register 483): X ₀₀ = >Uearth permanent fault (PE) X ₀₁ = >Uearth X ₀₂ = Transient PE towards busbar X ₀₃ = Transient PE towards line X ₀₄ = Transient towards busbar X ₀₅ = Transient towards line X ₀₆ = Short circuit towards busbar X ₀₇ = Short circuit towards line X ₀₈ = Short circuit undirected X ₀₉ = reserved X ₁₀ = reserved X ₁₁ = Pulse detection X ₁₂ = Short-circuit to earth: towards busbar X ₁₃ = Short-circuit to earth: towards line X ₁₄ = Short-circuit to earth: undirected X ₁₅ =reserved	1.21
473	0x01D8	R/W	ms	100 bis 500 Schritt:10	Relay 3 wipe time	1.21
474	0x01D9	R/W	ms	100 bis 500 Schritt:10	Relay 4 wipe time	1.21
475	0x01DA	R/W	-	1, 2 oder 4	Relay 3 contact type: <i>analogous to register 452</i>	1.21
476	0x01DB	R/W	-	1, 2 oder 4	Relay 4 contact type: <i>analogous to register 452</i>	1.21
477	0x01DC	R/W	-	1 to 15	relay 1 to 4 NO/NC contact 0 = NO contact 1 = NC contact	1.25

					<p>X₀₀ = relay 1 X₀₁ = relay 2 X₀₂ = relay 3 X₀₃ = relay 4 X₀₄ to X₁₅ = reserved</p>	
478	0x01DE	R/W	-	0 or 1	<p>Relay 1 status function 0 = off (normal function like relay 2 to 4) 1 = status function</p>	1.25
480	0x01E0	R/W		0 bis 63	<p>Relay 1 function part 2 (part 1 see register 450): X₀₀ = sin(phi) towards busbar X₀₁ = sin(phi) towards line X₀₂ = cos(phi) towards busbar X₀₃ = cos(phi) towards line X₀₄ = no voltage on all conductors X₀₅ = no voltage on any conductors X₀₆ = cos(phi) undirected</p>	2.04
481	0x01E1	R/W		0 bis 63	<p>Relay 2 function part 2 (part 1 see register 451): X₀₀ = sin(phi) towards busbar X₀₁ = sin(phi) towards line X₀₂ = cos(phi) towards busbar X₀₃ = cos(phi) towards line X₀₄ = no voltage on all conductors X₀₅ = no voltage on any conductors X₀₆ = cos(phi) undirected</p>	2.04
482	0x01E2	R/W		0 bis 63	<p>Relay 3 function part 2 (part 1 see register 470): X₀₀ = sin(phi) towards busbar X₀₁ = sin(phi) towards line X₀₂ = cos(phi) towards busbar X₀₃ = cos(phi) towards line X₀₄ = no voltage on all conductors X₀₅ = no voltage on any conductors X₀₆ = cos(phi) undirected</p>	2.04
483	0x01E3	R/W		0 bis 63	<p>Relay 4 function part 2 (part 1 see register 471): X₀₀ = sin(phi) towards busbar X₀₁ = sin(phi) towards line X₀₂ = cos(phi) towards busbar X₀₃ = cos(phi) towards line X₀₄ = no voltage on all conductors X₀₅ = no voltage on any conductors X₀₆ = cos(phi) undirected</p>	2.04

Customer registers (Register 501 to 600)						
501	0x01F5	R/W	-	0 to 65535	Registers for Customer Values will be saved in internal EEPROM (16-Bit value) Registers can be used e.g. to write: - customer inventory number - location code - last battery exchange information (like 1012 for October 2012) - date of installation (like 1012 for October 2012)	1.21
502	0x01F6	R/W	-	0 to 65535	<i>analogous to register 501</i>	1.21
503	0x01F7	R/W	-	0 to 65535	<i>analogous to register 501</i>	1.21

10.4 Datapoint list - register mapping “SNH 1.7”

Register		R/W	Function Code	Values	Description	From firm-ware Version
dec	hex					
2	0x0002	W	0x05	1	Reset all short circuit and earth fault indications	1.21
10	0x000A	R	0x02	0 or 1	Earth fault status on any phase: 0 = no fault detected, 1 = fault detected	1.21
11	0x000B	R	0x02	0 or 1	Short circuit or earth fault on phase 1: 0 = no fault detected, 1 = fault detected	1.21
12	0x000C	R	0x02	0 or 1	Short circuit or earth fault on phase 2: 0 = no fault detected, 1 = fault detected	1.21
13	0x000D	R	0x02	0 or 1	Short circuit or earth fault on phase 3: 0 = no fault detected, 1 = fault detected	1.21
16	0x0010	R	0x02	0 or 1	Short circuit in bus bar direction	1.21
17	0x0011	R	0x02	0 or 1	Short circuit in cable direction	1.21
18	0x0012	R	0x02	0 or 1	Earth fault (only qu2) and short circuit to earth (with priority) in bus bar direction	1.21
19	0x0013	R	0x02	0 or 1	Earth fault (only qu2) and short circuit to earth (with priority) in cable direction	1.21
8000	0x1F40	W	0x06	15395	Set fault on L1, L2 and L3 (short circuit and pulse)	1.21
20000 20001	0x4E20 0x4E21	R	0x03	float32	Current measurement L1 (amount)	1.21
20002 20003	0x4E22 0x4E23	R	0x03	float32	Current measurement L2 (amount)	1.21
20004 20005	0x4E24 0x4E25	R	0x03	float32	Current measurement L3 (amount)	1.21
20006 20007	0x4E26 0x4E27	R	0x03	float32	Current measurement IO (amount)	1.25
20008 20009	0x4E28 0x4E29	R	0x03	float32	Voltage measurement L12	1.25
20010 20011	0x4E2A 0x4E2B	R	0x03	float32	Voltage measurement L23	1.25
20012 20013	0x4E2C 0x4E2D	R	0x03	float32	Voltage measurement L31	1.25
20014 20015	0x4E2E 0x4E2F	R	0x03	float32	Voltage measurement L1	2.04
20016 20017	0x4E30 0x4E31	R	0x03	float32	Voltage measurement L2	2.04
20018 20019	0x4E32 0x4E33	R	0x03	float32	Voltage measurement L3	2.04
20020 20021	0x4E34 0x4E35	R	0x03	float32	Voltage measurement Une	2.04
20046	0x4E4E	R	0x03	float32	Apparent power S	1.25
20048	0x4E50	R	0x03	float32	Active power P	1.25
20050	0x4E52	R	0x03	float32	Reactive power Q	1.25
21100	0x526C	R	0x03	float32	Current measurement L1 (with sign)	1.21

21102	0x526E	R	0x03	float32	Current measurement L2 (with sign)	1.21
21104	0x5270	R	0x03	float32	Current measurement L3 (with sign)	1.21
22000	0x55F0	R	0x03		Indicator status summary: X ₀₀ to X ₀₃ = reserved X ₀₄ = self test result not ok (internal fault present) X ₀₅ = self test result ok X ₀₆ = self test running (1=yes / 0=no) X ₀₇ = external power supply (1=yes / 0=no) X ₀₈ to X ₁₂ = reserved X ₁₃ = Error, e.g. battery empty X ₁₄ to X ₁₅ = reserved	1.21
22100	0x5654	W	0x06	1	Start self test (Result in Register 22000)	1.21
22105 to 22108	0x5659 to 0x565C	R/W	Read:0x03 Write:0x10		Set time and date: Register 22105: milliseconds Register 22106: hours: X ₁₂ X ₁₁ X ₁₀ X ₀₉ X ₀₈ minutes: X ₀₆ X ₀₅ X ₀₄ X ₀₃ X ₀₂ X ₀₁ X ₀₀ Register 22107: month: X ₁₁ X ₁₀ X ₀₉ X ₀₈ day of week: X ₀₇ X ₀₆ X ₀₅ (Mo=1,...) day: X ₀₄ X ₀₃ X ₀₂ X ₀₁ X ₀₀ Register 22108: year: X ₀₆ X ₀₅ X ₀₄ X ₀₃ X ₀₂ X ₀₁ X ₀₀ (only last two digits, e.g. „19“ for 2019)	1.21

11. Servicing/Cleaning/Spare parts

The service interval depends on the operating and environmental conditions. The service interval can be determined by the customer himself. An interval of 5 years is recommended. In service cases please use our service documentation from the download center of our homepage www.a-eberle.de.

11.1 Firmware update

For the firmware update a power supply must be connected. The firmware update is performed via the internal SD card of the device. To copy the new firmware on the SD card, first the front plate of the EOR-1DS must be dismantled, then the SD card has to be taken out and with the help of a computer the new firmware ("image.hex") has to be copied in the root folder of the SD card. The current firmware version is available in the download center on our homepage www.a-eberle.de. The detailed process to update the firmware in the menu of the EOR-1DS is explained in chapter 9.6.4.

11.2 Cold start

On the EOR-1DS a cold start can be performed, when the operating button is pushed continuously for at least 30 seconds. The green LED (if a voltage source is provided) turns off. As soon as the operating button is released the green LED shows through a short flash that the cold start is performed. During this the firmware restarts, the parameterization and the real time clock remain unchanged.

11.3 Spare parts

Spare parts can be requested from A. Eberle GmbH & Co. KG.

11.4 Cleaning

Use a soft, lightly wet and fuss-free cloth. Pay attention that no humidity enters the case. Use no window cleaner, sprays, household cleaners, solvents, alcoholic cleaners, ammonia solution or scouring agent for cleaning.

If there is high staining in the inside caused by incorrect usage it is recommended to send the device back to the producer. If there is a large amount of dust on the circuit boards the insulation coordination could fail.

Dusts are generally hygroscopic and can bypass creepage distances. By this reason it is recommended to operate the device, if possible, with closed case door.

NOTICE!

Cleaning the device with the wrong cleaning agent!

Damaging the surface of the device and detaching of labels

➡ Pay attention to the above listed mediums

12. Standards and Laws

- LVD 2014/35/EU Low Voltage Directive
- EMC 2014/30/EU Electromagnetic Compatibility (EMC)
- DIN EN 61010-1:2020-03 Safety requirements for electrical equipment for measurement, control, and laboratory use - Part 1: General requirements
- DIN EN 61326-1:2013-07 Electrical equipment for measurement, control and laboratory use - EMC requirements - Part 1: General requirements
- CISPR 11:2015 (EN55011) Industrial, scientific and medical equipment - Radio-frequency disturbance characteristics - Limits and methods of measurement
- DIN EN 82079-1 1 Preparation of instructions for use - Structuring, content and presentation – Part 1: General principles and detailed requirements

13. Disassembly & disposal

⚠ DANGER!	Danger of electric shock!
<ul style="list-style-type: none">➤ Assemble/disassemble the EOR-1DS indication unit and the current sensors when the system is de-energised➤ Comply with the 5 rules of safety	

Directive 2012/19/EU, better known as the WEEE2 Directive, deals with the return and recycling of waste electronic and electrical equipment in order to recover valuable raw materials. This concerns all A. Eberle products marked with the symbol of a waste garbage can shown.

➤ Our WEEE registration number is: **DE 37396879**

For old devices, please also note the information on our homepage:

<https://www.a-eberle.de/en/about-us/take-back-recycling/>



14. Warranty

We guarantee that every product A. Eberle GmbH & Co KG is free from material and manufacturing defects under normal use. The detailed conditions for the warranty can be found in our general terms and conditions of business under:

<https://www.a-eberle.de/en/general-terms/>

To claim warranty, please contact A. Eberle GmbH & Co KG in Nuremberg or use the RMA formular on our Homepage under www.a-eberle.de.



A. Eberle GmbH & Co. KG

Frankenstraße 160
D-90461 Nürnberg

Tel.: +49 (0) 911/62 81 08-0
Fax: +49 (0) 911/62 81 08 96
E-Mail: info@a-eberle.de

<http://www.a-eberle.de>

Edition of: 08.08.2024

Version: BA_EOR-1DS_EN_20240808.docx

Copyright 2013 - 2024 A. Eberle GmbH & Co. KG

Subject to change without prior notice.